

A NEW PRINCIPLE OF DIGITAL FRACTIONAL FREQUENCY SYNTHESIZER

Milan Stork

e-mail:stork@kae.zcu.cz

*University of West Bohemia, Faculty of Electrical Engineering, Department of Applied Electronics,
P.O.Box 314, 30614 Plzen, Czech Republic*

Key words: Frequency synthesizer, phase locked loop, counter, register

ABSTRACT

This paper describes architecture of a new pure digital frequency synthesizer based on pulse generators, counters and a register. The technique described here is much simpler than other method. Presented synthesizer is the suitable for the design of VLSI architectures or for programmable Large Scale Integration circuits.

I. INTRODUCTION

The frequency synthesizer can be described as an active electronic device that accepts a reference frequency and then generates one or more new frequencies as defined by a control word. Modern electronic and telecommunication systems demand frequency synthesizer of high resolution, wide bandwidth and fast switching speed. Conventional frequency synthesis techniques existing today may be classified as the following three types:

- Phase-locked loop (PLL) based, or "indirect"
- Mixer / filter / divide, or "direct analog"
- Direct digital synthesis (DDS)

Each of these methodologies has advantages and disadvantages. Direct analog synthesis uses the functional elements of multiplication, division and other mathematical manipulation to produce the desired frequency, but this method is a very expensive. DDS uses logic and memory to digitally construct the desired output signal. On the output, digital-to-analog (D/A) converter is used to convert the digital signal to analog domain. PLL-based frequency synthesis has been widely used in industry. However, one of major difficulties associated with PLL-based technique is that a PLL with wide frequency range cannot be achieved easily. Also, fast switching is difficult to achieve. Typically, the output frequency step size of this method is the reference frequency. With fractional-N synthesis technique [1], finer frequency control can be achieved; however, these systems typically have very narrow bandwidth.

In this paper a new simple architecture of digital frequency synthesizers with square wave output is presented. Described synthesizer is the most suitable for

the design of VLSI architectures or for programmable Large Scale Integration. On the other hand, this synthesizer has a disadvantage in low output frequency, but this can be overcome by using this synthesizer together with phase locked loop.

The aim of frequency synthesis is to generate arbitrary frequency f_X , from a given standard frequency f_S , it means to solve the equation (1):

$$f_X = k_X * f_S \quad (1)$$

where k_X in the simplest case is a fraction formed by small, relatively prime integers. That is,

$$k_X = X_I / Y_I \quad (2)$$

and the synthesizer is reduced merely to chain of one frequency divider and one multiplier. If X_I and Y_I in (2) are products of small prime numbers, the synthesizer may be realized by chain of frequency multipliers and dividers. However, there are difficulties with hardware solutions, mainly generation of spurious signals and frequent enhancement of the phase noise level.

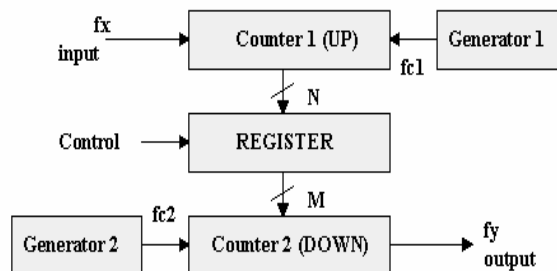

Figure 1. Block diagram of the digital synthesizer

II. PRINCIPLES OF THE NEW SYNTHESIZER

In the Figure 1, there is a block diagram of the digital frequency synthesizer [2]. It consists of Counter 1, which counts up frequency f_{C1} gated by input frequency f_X . Parallel output from Counter 1 is connected to Register

input and Register output is connected to preset inputs of Counter 2 which counts down frequency f_{C2} . On the output of this Counter 2 there is frequency f_Y . It is expected, that $f_{C1} > f_X$. Number $C1$ which is stored in Counter 1 during the period of the f_X is given by (3):

$$C1 = f_{C1}/f_X \quad (3)$$

This number is written in the Register, where his value can be changed by the Control to $C2$:

$$C2 = g(C1) \quad (4)$$

where $g(.)$ denote some function of $C1$.

Number $C2$ is given by (5):

$$C2 = f_{C2}/f_Y = g(C1) = g(f_{C1}/f_X) \quad (5)$$

Output frequency f_Y can be expressed from (5) by (6):

$$f_Y = f_{C2}/g(f_{C1}/f_X) \quad (6)$$

When, for example function $g(.) = 1/k_1$ (which can be simply realized by shift binary number in the Register) output frequency f_Y is given by (7):

$$f_Y = f_{C2} * k_1 * f_X / f_{C1} \quad (7)$$

Equation (7) shows, that output frequency f_Y is a products of frequency f_{C2} , k_1 and input frequency f_X divided by frequency f_{C1} . All of these parameters can be individually set. The length of the counters and registers must be sufficient to prevent overrun. If the binary counter is expected, then minimal length L of the Counter 1 [bit] is given by (8):

$$L \Rightarrow \text{Ceil}(\log_2(f_{C1MAX}/f_{XMIN})) \quad [\text{bit}] \quad (8)$$

where f_{C1MAX} and f_{XMIN} are maximal clock and minimal input frequency and Ceil function converts numeric value to an integer by returning the smallest integer greater than or equal to its argument. In Figure 2, the synthesizer is shown as a building block.

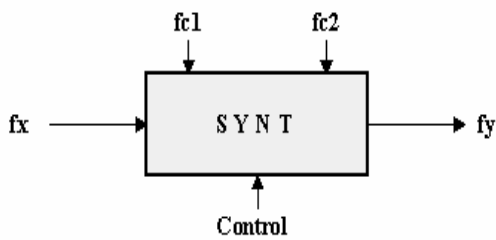

Figure 2. The digital frequency synthesizer as a building block

III. DIGITAL SYNTHESIZER AND PHASE LOCKED LOOP

The phase locked loop (PLL) works as a feedback system shown in Figure 3 [3]. The task of PLL is to maintain coherence between input (reference) signal frequency, f_i , and the respective output frequency, f_o , via phase detector (PD) [4]. When PLL locks onto a reference signal the output frequency is given by (9):

$$f_o = N * f_i \quad (9)$$

where N is an integer divide number of divider.

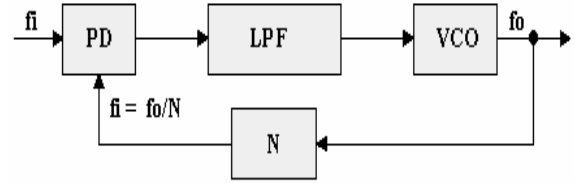

Figure 3. Block diagram of the basic Phase-Locked Loop. PD - phase detector, LPF - low pass filter, VCO -voltage controlled oscillator, N - frequency divider by N (N is integer number).

Normally, frequency dividers can only produce integer divide ratios (N is integer). Fractional division is accomplished by alternating the instantaneous divide number between N a $N+1$, but this causes phase modulation on the VCO [5]. Therefore a different complicated technique is used for correction of this error [6]. In Figure 4, the SYNT circuit is used in PLL [7].

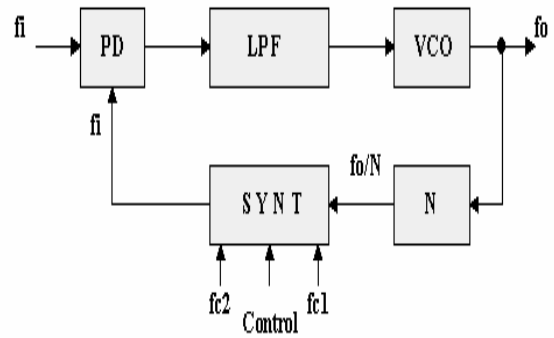

Figure 4. The Phase-Locked-Loop with the digital frequency synthesizer placed in feedback

Frequency on the SYNT input is f_o/N and frequency on the SYNT output is given by (10):

$$f_i = f_{C2} * k_1 * f_o / (f_{C1} * N) \quad (10)$$

From (10) we can derive the frequency of voltage controlled oscillator which is shown in (11):

$$f_o = f_{C1} * N * f_i / (f_{C2} * k_1) \quad (11)$$

In case that number $C2$ in register is given by (12) (binary number $C1$ is multiplied by m_1 , e.g. register is shifted to left, instead of divided by k_1), the frequency of voltage controlled oscillator is given by (13):

$$C2 = m_1 * C1 \quad (12)$$

$$f_o = f_{C1} * m_1 * N * f_i / f_{C2} \quad (13)$$

From the (13) we can see, that output frequency f_o is a function of integer m_1 , N and clock frequencies f_{C1} , f_{C2} [8, 9, 10, 11].

IV. ERROR REDUCTION IN SYNTHESIZER

The digital synthesizer shown in Figure 1, has a following disadvantage. When the numbers in counters are small (numbers are integer), the output frequency is not accurate. This error can be improved by adaptive control shown in Figure 5.

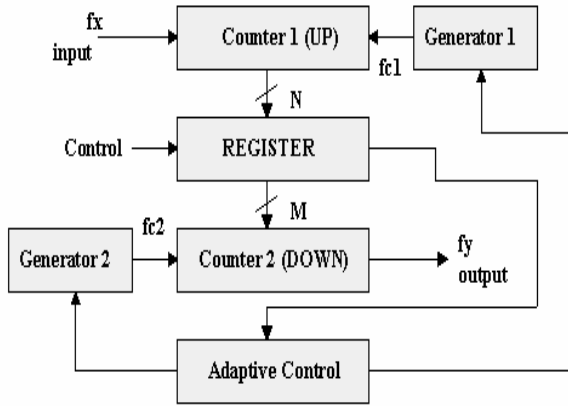

Figure 5. Possibility of the adaptive control using in the digital frequency synthesizer.

The Figure 5 is the almost the same as Figure 1, only adaptive control is added. Adaptive control block reads the contents of the Register. When the number is too small, the frequency of Generator 1 is multiplied and also frequency in Generator 2 is multiplied, so that the ratio of $f_{C1}/f_{C2} = \text{constant}$. On the other hand, if number in Register is too big, the frequencies of both generators are divided by the same number.

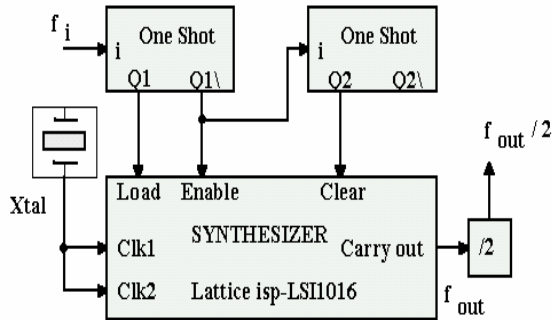

Figure 6. Example of the digital frequency synthesizer realized by using Lattice isp-LSI1016 IC's, oscillator and 2 one shot devices. In this experiment, Clk1 and Clk2 were connected together.

V. THE DIGITAL SYNTHESIZER MAIN ADVANTAGES AND DISADVANTAGES

The digital synthesizer which was described (Figure 1) has following disadvantages:

- Accuracy depends on integer number in Counters
- Not suitable for high output frequency
- Only square wave output

The main synthesizer advantages are:

- Pure digital architecture
- Wide range
- No setting problems
- Stable
- Fast response
- Easily realized by programmable logic array
- Easily reprogrammable and reconfigurable
- Microcontroller adaptive control can be simply added for quality improving.

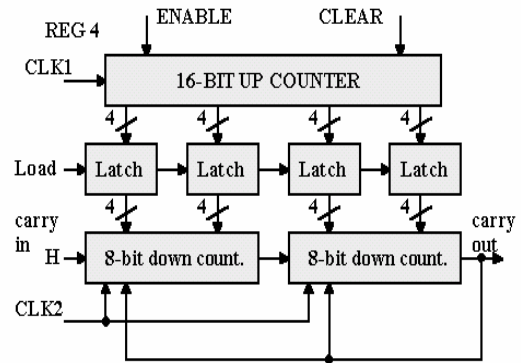

Figure 7. Internal block diagram of the digital frequency synthesizer based on programmable logic Lattice isp-LSI1016

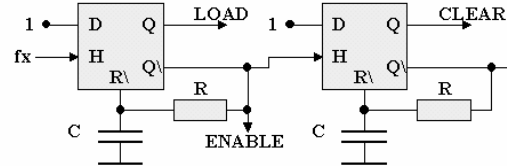

Figure 8. The dual one shots circuit used in experimental 16-bit digital frequency synthesizer.

VI. THE EXPERIMENTAL RESULTS

The digital synthesizer was designed and built according to the above discussion. The synthesizer requires e.g. one Lattice ispLsi 1016 device (in-system programmable Large Scale Integration circuit), X-tal oscillator and two peripheral one shot devices (Figure 6).

Internal block diagram of the 16-bit synthesizer is shown in Figure 7. The connection of two one shot devices is shown in Figure 8. For device testing, $f_{C1} = f_{C2} = 31.111$ MHz and $k_I = 1$, so according to the relation (7), the ideal output frequency is:

$$f_Y = f_X$$

Photography of PC board of synthesizer is shown in Figure 9. Two, different delays one shot circuits were tested. For delay of $0.6 \mu s$ (load + clear) the input frequency f_x , output frequency f_y were measured and CI

number in up-counter and $C2$ number in down-counter were computed and number difference $diff = C1 - C2$ was also computed. The results are shown in Table 1. From Table 1 it can be seen, that differences are constant and error in frequency can be easily corrected. For delay of 60 ns (load + clear) input and output frequencies are the same to 1 MHz. For frequency 1 MHz to 3 MHz, the results are in Table 2. For $f_{C1} = f_{C2} = 31.111$ MHz, the maximal input frequency is approx. 3.5 MHz for good function. Minimal input frequency (to avoid an overflow of 16-bit counter) is 476 Hz.

f_x [Hz]	f_y [Hz]	$C1$	$C2$	$diff$
1502	1502	20713	20713	0
2010	2014	15478	15460	18
4008	4016	7762	7745	17
6004	6026	5181	5162	19
10008	10068	3108	3090	18
20004	20258	1555	1535	20
40000	40980	777	759	18
100000	106600	311	291	20

Table 1. Input and output frequencies for 600 ns delay (load + clear), f_x - input frequency, f_y - output frequency, $C1$, $C2$ are the numbers in Counter1 and Counter 2, $diff$ - counters difference ($C1 - C2$)

f_x [kHz]	f_y [kHz]
Input frequency	Output frequency
2	2
6	6
10	10
100	100
400	400
800	800
1082.1	1083.0
2020	2032
3275	3276

Table 2. Input and output frequencies for 60 ns delay (load + clear).

The experimental digital synthesizer was also used in PLL feedback to produce a fractional PLL. The output frequency spectrum is shown in Figure 10.

At the present time, the digital synthesizer was also designed in VHDL language. This design was realized and tested on Altera FPGA development board with EP20K200E device. The clock signals f_{C1} and f_{C2} are driven by a 33.3 MHz free running oscillator. The whole design consumes only 6 % of available logic cells. Despite of a low demand of the logic cells the counter 1 is 24 bit long and the counter 2 is 32 bit long. This width

provides the input frequency range from 2 Hz up to 6.2 MHz (for 33.3 MHz clock). The 8 bit difference between the width of counters allows to divide or multiple output frequency up to 8th power of 2. Fine tuning of the output frequency is provided by the combinational logic for adding or subtracting 23 bit integer numbers to the content of the register.

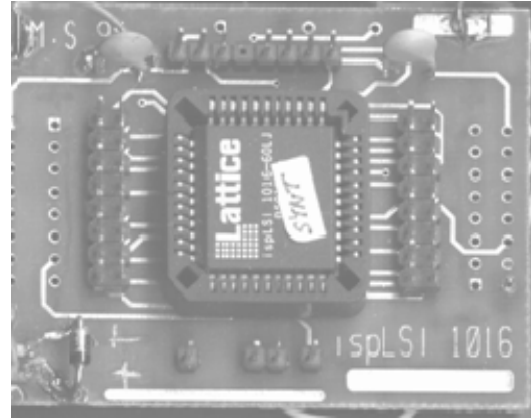

Figure 9. PC board of experimental digital synthesizer. Based on one Lattice ispLsi 1016 device PC board size: 60 x 45 mm

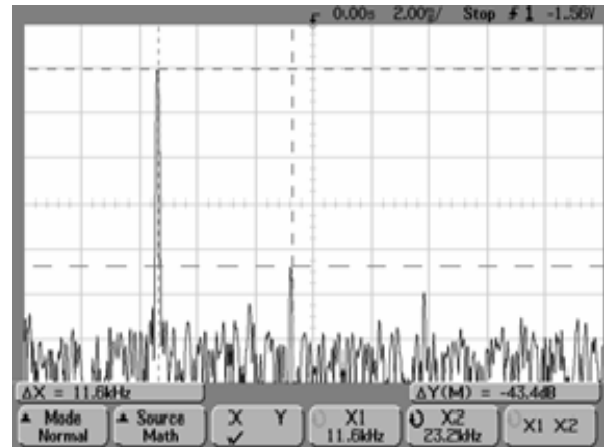

Figure 10. The output signal frequency spectrum of the fractional PLL, based on digital frequency synthesizer.

VII. CONCLUSION

The frequency synthesizers form, which is the basic of most radio system designs and their performance is often key to the overall operation. They are also an important building block in almost all digital and mixed signal integrated circuits as a clock multiplier. Apart from the usual integer-N PLL implementation of the clock multiplier, where a voltage controlled oscillator is locked to a clean reference clock [9, 10]. The architectures based on a Delay-Locked Loop (DLL) have been successfully used recently as a clock multipliers. The main disadvantage of conventional DLL's, however, is their limited phase capture range.

A new design technique of the frequency synthesizer has been presented in this paper. The presented digital frequency synthesizer was patented in the Czech Republic. Schemes for direct and indirect synthesizers were shown and basic equations and block diagram were also described. The digital frequency synthesizer was realized as 16 bit device, by using Lattice ispLsi 1016 IC's (Counter max. frequency 80 MHz), and experimental results were introduced. It is important to note, that delay, caused LOAD and CLEAR can be easily corrected. The synthesizer can be best of all realized simply by using FPGAs or another types of programmable logic. The synthesizer is suitable for fractional frequency multiply, divide or for another frequency processing. Main advantage is that synthesizer has a fully digital structure and also, there are no stability problems. Also possibilities of wide range input frequency is important. The digital synthesizer can be used with phase-locked loop for simple production of the fractional PLL. In near future, the simple adaptive control will be added in the digital frequency synthesizer for better function on higher frequency.

ACKNOWLEDGMENT

This research work has been supported by *Departemnt of Applied Electronics and Telecommunications University of West Bohemia, Plzen, Czech Republic*

REFERENCES

1. V. F. Kroupa, Direct Digital Frequency Synthesizers, New York, IEEE Reprint Press Book, 1998.
2. M. Stork, A Digital Frequency Synthesizer, Czech Republic Patent, AO 256872, October 30, 1989.
3. V. F. Kroupa, Theory of Phase-Locked Loops and Their Applications in Electronics (in Czech language), Academia Praha 1995.
4. M. Curtin, P. O'Brien, Phase-Locked Loops for High-Frequency Receivers and Transmitters - Part 1, Analog Dialogue 33-3, 1999, pp. 1-4, Part 2, Analog Dialogue 33-5, 1999, pp. 1-5, Part 3, Analog Dialogue 33-7, 1999, pp. 1-5, Analog Devices, <http://www.analog.com/>
5. D. D. Danielson, S. E. Froseth, A Synthesized Signal Source with Function Generator Capabilities, Hewlett-Packard Journal, Vol. 30, no. 1, January 1979, pp. 18-26.
6. J. Chodora, A Digitally Corrected Fractional-N Synthesizer, Hewlett-Packard Journal, Vol. 44, no. 2, April 1993, pp. 44.
7. J. Surber, L. McHugh, Single-Chip Direct Digital Synthesis vs. the Analog PLL, Analog Dialogue, Vol. 30, no. 3, 1996, pp.12-13, Analog Devices, <http://www.analog.com/>
8. M. Stork, New Fractional Phase-Locked Loop Frequency Synthesizer Using a Sigma-Delta Modulator, 14th International Conference on Digital Signal Processing, DSP 2002, Santorini - Greece, July 2002, ISBN 0-7803-7503-3, Volume 1, pp. 367 - 370.
9. M. Stork, Voltage to Frequency Converter, 12th IMEKO TC4 International Symposium, Electrical Measurements and Instrumentation, Zagreb, Croatia, September 2002, ISBN 953-96093-8-0, Proceedings Part 2, pp. 464 - 467.
10. M. Stork Frequency Synthesizer Based on Counters, 4th International Conference on Measurement, Smolenice, Slovak Republic, 2003, ISBN 80-967402-6-1, pp. 439-442.
11. M. Stork, Counter Based Frequency Synthesizer, XVII IMEKO World Congress, Dubrovnik, Croatia, 2003, ISBN 953-7124-00-2, pp. 933-937.