

A Security Assessment for Slow Coherency Based Defensive Islanding

Mohammed Mahdi, V. M. Istemihan Genc

Istanbul Technical University,
Department of Electrical Engineering
34469, Istanbul, Turkey
mahdi@itu.edu.tr, gencis@itu.edu.tr

Abstract

Among the power system corrective controls, defensive islanding is considered as the last resort to secure the system from severe cascading contingencies. The primary motive of defensive islanding is to limit the affected areas as soon as possible to maintain the stability of the resulting subsystems and to reduce the total loss of load in the system. The design of the defensive islanding must address the questions of where and when to island the system to ensure minimum impact and the recovery of the affected portion of the system. In this paper, the critical islanding time is explored as a security index for applying the defensive islanding where the boundaries of the islands are decided by using the slow coherency concept between generators. The computations are performed on a test system to specify the maximum allowed time for operators to apply islanding before falling in blackout due to some critical contingencies.

1. Introduction

Due to the continuous increase in the demand, power systems are operated near their stability limits where they become more vulnerable to the disturbances. Such severe disturbances can be caused by various reasons such as, earthquakes, hurricanes, human operation errors, control system failures, hidden failures in protection system, malicious attacks, weak connections, and a host of other factors [1, 2]. This increases the need for the design of comprehensive system control strategies to prevent the system from losing its stability, which may lead to catastrophic failures [3, 4]. Therefore, the need for designing a comprehensive system control strategy is receiving more attention.

When a severe disturbance occurs in the power system, it could spread in the system because of the interconnections inside the power system which could endanger the stability of the power system. As a consequence of such a disturbance, tripping of the lines in the system may occur which lead to passive islanding situation, where the power system separates into electrically separated islands [5]. Passive islanding can cause the power system to lose the stability which lead to blackout. Defensive islanding can be considered as one of the efficient control strategies for such circumstances. Defensive islanding controls the way which the islands is formed to limit the impairment of the power system reliability. The boundaries between the islands are designed to limit the disturbance inside one island from the system, and maintain stability throughout the rest of the system. The timing of the formation of these islands is a critical decision because the defensive islanding must be carried out before system deteriorates significantly [5, 6].

Defensive islanding is considered as the final resort to save the system from losing the synchronous stability which leads to

blackout [1, 2, 4, 7, 8]. It has been shown that if a well-designed defensive islanding scheme had been applied promptly to the widespread blackout occurred in the Northeastern United States and in Southeastern Canada, then the power system would have not suffered from any blackout [4].

Slow coherency based islanding is one of the most effective approaches that can be used for defensive islanding [1, 2, 4, 7, 8]. The slow coherency concept comes from the observation that in post-fault transients, only the generators close to the fault location respond with the fast inter-machine oscillations while the other generators further away from the fault swing together in groups in which they are “in phase” with the slow modes [7]. The approach is based on defining the areas by grouping the generators according to their coherency [7]. Since the slow coherency algorithm considers the dynamic behaviors of the generators in large-scale power systems, the solutions not only maintain good active power generation and load balance, but also provide good dynamic transient performance during the islanding process [7, 8].

The answer to the question of when to island a power system is important since islanding too early would mean an unnecessary heavy interference in the power system, which of course has a high cost, while waiting too long would mean that a blackout could happen in the power system, which has a higher cost. In [5] and [6], prony analysis and trained decision trees are utilized to decide when to island.

This paper explores the security assessment of the power system when a defensive islanding is one of the alternatives in case of some critical contingencies. The slow coherency based defensive islanding is assumed to be implemented to successfully restore the stability of the power system. Simulations are performed on a 68-bus 16-generator test system [9] to find the point of no return, which is the critical islanding time (CIT). CIT specifies the maximum allowed time for the power system operators to apply the islanding scheme on the power system before losing stability and a blackout could happen. An index, islanding security index (ISI), is also defined to specify the security margin for the islanding scheme, and how far the system is away from the point of no return.

2. Slow Coherency Based Islanding

The slow coherency concept in power systems is an application of the two-time-scale method [7]. The application is based on the observation of electromechanical oscillations occurring in large-scale power systems. Oscillations in power systems can be classified into two classes, local (or intra-area) modes in the range 1-3Hz and inter-area modes, usually less than 1 Hz. After the fast intra-area dynamics decay, the generators in the same area may continue to swing together as they are “coherent” with respect to the slow modes. Using the concept of

slow coherency, the generators can be grouped into coherent groups with respect to the inter-area modes [7]. The disturbances can be successfully contained within one coherent group (island), by opening the weaker connections between the islands just before the disturbances can propagate by these connections [6].

The two-time-scale method [7] assumes that the state variables of an n -th order system are divided into r slow states, and $(n-r)$ fast states, in which the slow states represent r coherent groups based on slow coherency. The user provides an estimate for the number of groups according to the eigenvalues of the system [7]. Both the nonlinear power system models and their linearized models can be used to apply the two-time-scale method. The linearized model of power system consisting of n generators, each of which is modeled by the classical generator model, can be represented as

$$\ddot{x} = A x = (M^{-1} K) x \quad (1)$$

where x is the vector of changes in the rotor angles,

$$x = [\Delta\delta_1 \ \cdots \ \Delta\delta_n]^T \text{ and } M =$$

$$\text{diag}(2H_1/\omega_s, \ \cdots, \ 2H_n/\omega_s),$$

where H_i is the inertia constant and ω_s is the synchronous speed. The elements of K ,

$$k_{ij} = V_i V_j [B_{ij} \cos(\delta_i - \delta_j) - G_{ij} \sin(\delta_i - \delta_j)], \quad i \neq j,$$

$$k_{ij} = -\sum_{j=1, j \neq i}^n k_{ij},$$

where V_i is the voltage behind the transient reactance and G_{ij} and B_{ij} are the conductance and the susceptance of the (i,j) -th entry of the relevant network admittance matrix, respectively.

Using the augmented system state matrix A , the coherency based grouping algorithm [7] is applied. It can be combined with the sparsity theorem presented in [10] to include the load buses into the islanding scheme where a fictitious generator is connected to each load bus with a small inertia compared to the inertia constants of the real generators of the system. The fictitious generators have no transient reactance.

The steps of the slow coherency grouping algorithm [7] applied to the linearized model of a power system are as follows:

1. Choose the number of groups (r) and the slowest modes.
2. Compute an eigenbasis matrix U of the r slowest modes.
3. Apply Gaussian elimination with complete pivoting to U and obtain the set of r reference states.
4. Calculate U_1 by ordering the first r rows of U according to the order found in Step 3.
5. Calculate $L = U U_1^{-1}$.
6. Assign other generators to the coherent groups according to the largest entry in each row of L .

Alternatively, in order to determine the coherency based grouping of the machines and, thus, islanding schemes, other algorithms, such as using self-organizing maps neural networks or hierarchical clustering [11], which utilize the post-fault time-domain responses of the nonlinear system models can also be applied.

3. Islanding Security Index

This paper explores the time when “the point of no return” occurs in case an islanding scheme is to be activated. This question is of crucial importance as islanding too early would mean an unnecessary heavy intervention, while waiting too long

would mean that a blackout could happen. To answer this question, two terms, the critical islanding time and islanding security index are defined.

The critical islanding time (CIT), is defined as the maximum allowed time for the power system operators to apply the islanding scheme on the power system before a blackout. If the power system operators attempts to apply the islanding scheme after the CIT, it means that they reached the point of no return and no benefits can be obtained from islanding after that. The CIT can be calculated by using iterative simulations performed on a system model for each scenario of applying the islanding scheme. The idea of calculating the CIT is similar to the idea of calculating the critical clearing time (CCT). The calculation of CIT is based upon a dichotomic procedure which searches within a user-supplied starting interval. Each step of the dichotomic search is performed by an automatic run of the main simulation engine generating stable and unstable states. Through this procedure, the longest time interval between the inception of the disturbance and the islanding that still maintains stability is computed as the CIT.

The islanding security index (ISI), which explains how much the security region for the operators for a specific scenario to apply the islanding scheme is defined as follows:

$$ISI = \frac{CIT - IT}{CIT} \quad -\infty < ISI < 1 \quad (2)$$

where, IT represents the actual islanding time at which the power system operators activated the islanding scheme. If ISI equals zero, it means that the power system operators activated the islanding scheme exactly at the CIT time, and the power system is at the edge between remaining stable and losing its stability. For $0 < ISI < 1$, the power system is in the secure region for islanding, and the system will remain stable after applying the islanding scheme, while for $-\infty < ISI < 0$, the power system will lose its stability even if the islanding scheme is applied, since the operators activated the islanding scheme too late.

4. Simulation Results

For applying the slow coherency based islanding, and calculating the two terms CIT and ISI, a 68-bus 16-generator test system is chosen. This test system is a much less detailed model of the U.S. Northeastern and Ontario system [9]. In the test system, only the New England system is represented in detail with generators numbered from G53 to G61, while the neighboring utility systems in New York, Pennsylvania, Michigan and Ontario are modeled with large equivalent generators numbered from G62 to G68. The full data of this system can be found in [9]. The one line diagram of the test system is shown in Fig. 1.

The slow coherency based islanding algorithm presented in [8], combined with the sparsity theorem in [10] is applied on the test system. After building the augmented system state matrix A in (1), firstly, the number of areas is specified. The objective is to find the weak connections between the areas. This can be accomplished by examining the separation between the imaginary parts of the eigenvalues of A in (1). The number of islands is chosen to be 5 according to the separation between the eigenvalues.

The eigenvector matrix U is computed for the five modes, and then Gaussian elimination is applied with complete pivoting to obtain the five reference generators of the islands. The reference generators are found as generators G57, G65, G66, G67 and G68. The islanding process separated the 9 generators of New England in one island, four neighboring generators representing New York

into another island, and three large generators into a single island, which means that the islanding process is consistent with the topology of the system. The results of the slow coherency based islanding are given in Table 1 and shown in Fig. 1. Also, this islanding scheme is the same as the ones in [11] that are found by using self-organizing maps neural networks or hierarchical clustering.

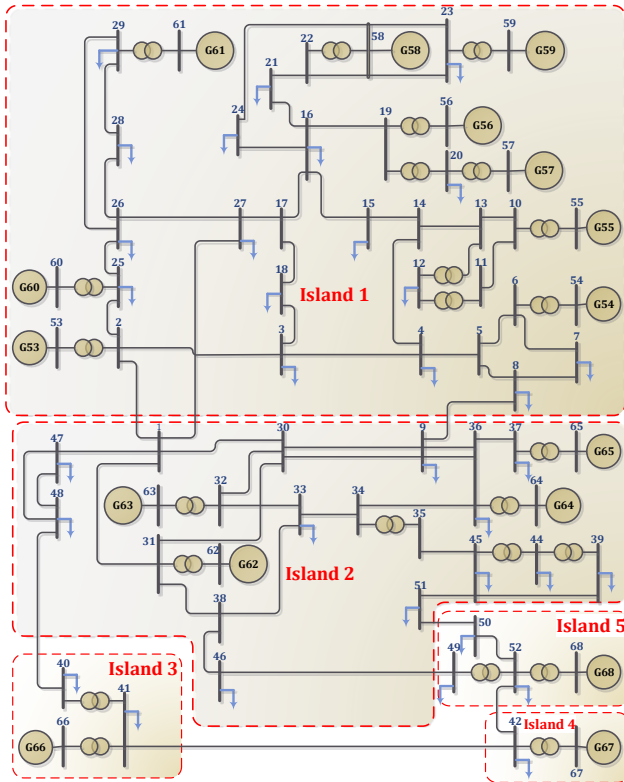

Fig. 1. One line diagram of the test system and the islands determined by the islanding scheme

Table 1. Slow coherency based islanding results

Island No.	Buses included in the island
Island 1	2, 3, 4, 5, 6, 7, 8, 10, 11, 12, 13, 14, 15, 16, 17, 18, 19, 20, 21, 22, 23, 24, 25, 26, 27, 28, 29, 53, 54, 55, 56, 57, 58, 59, 60, 61
Island 2	1, 9, 30, 31, 32, 33, 34, 35, 36, 37, 38, 39, 43, 44, 45, 46, 47, 48, 51, 62, 63, 64, 65
Island 3	40, 41, 66
Island 4	42, 67
Island 5	49, 50, 52, 68

For testing the efficiency of the islanding algorithm, and its ability of saving the system in the cases of severe contingencies, and for calculating the CIT and ISI, a contingency scanning of three-phase bolted faults cleared after 5 cycles is done on the system to specify the critical contingencies that have a response of instability. The islanding scheme will be applied for the critical contingencies for saving the system from instability and a possible blackout. The critical contingencies of the system are listed in Table 2.

Table 2. The set of critical contingencies for test system

No.	3-Phase bolted fault at bus	Line to be removed	CCT (Cycle)
1	48	40-48	-
2	40	48-40	-
3	45	51-45	-
4	51	45-51	-
5	50	52-50	-
6	52	50-52	-
7	50	51-50	-
8	51	50-51	-
9	41	40-41	-
10	40	41-40	-
11	29	28-29	4.5779
12	29	26-29	4.8592
13	22	21-22	4.8592

After specifying the critical contingencies (Table 2), the islanding scheme obtained is applied to the system for each case. For specifying the CIT for each critical contingency a computer program is run to perform iterative simulations with TSAT [12]. By means of the dichotomic search performed, the CIT value for each critical contingency is found and given in Table 3.

Table 3. The CIT for the critical contingencies of test system

No.	3-Phase bolted fault at bus	Line to be removed	CIT (second)
1	48	40-48	3.6834
2	40	48-40	3.6667
3	45	51-45	2.5000
4	51	45-51	2.4834
5	50	52-50	1.6167
6	52	50-52	1.6167
7	50	51-50	1.8500
8	51	50-51	1.8667
9	41	40-41	2.8167
10	40	41-40	3.0000
11	29	28-29	0.2500
12	29	26-29	0.3167
13	22	21-22	0.5167

As it can be seen from Table 3, the CIT for contingency no. 11 has the lowest value among of all the contingencies. In case of this contingency, the power system operators must act as fast as possible to apply the islanding scheme on the system as a way for saving the system from losing synchronism. On the other hand for the case of contingency no. 1 with the highest CIT of 3.6834 seconds, the power system operators may have enough time for applying less expensive corrective control methods, for example load shedding or generation rescheduling.

In order to show the effectiveness of the islanding scheme, and its ability of saving the power system from losing synchronism, and the importance of calculating the CIT and ISI, one of the cases from the set of contingencies in Table 3 is chosen: contingency no. 13, where a three-phase bolted fault on bus 22 is cleared after 5 cycles by removing the line connecting buses 21 and 22. The responses regarding to the generators' rotor angles after the fault are shown in Fig. 2, which shows that the system loses its stability. The islanding scheme obtained is applied with the appropriate load shedding needed for island 2, and the generator rescheduling for island 5. At first, the islanding scheme

is applied with islanding time less than the CIT, islanding time was chosen as 0.3 s, and ISI for that timing is found as 0.4194, which means that the power system is in the secure region for islanding. The generators' rotor angles after the islanding are shown in Fig. 3, and their speeds are shown in Fig. 4. As it can be seen from the figures the generators inside each island are running in synchronism, while they are asynchronous with respect to the other islands. The system in total is stable and the slow coherency based islanding is successful.

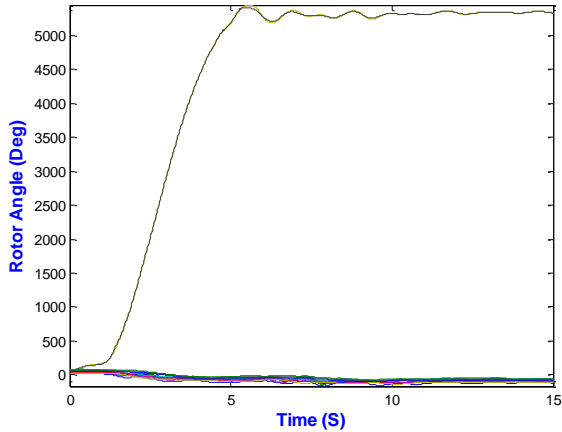

Fig. 2. Rotor angles after 3-phase bolted fault at bus 22 cleared by tripping line 22-21

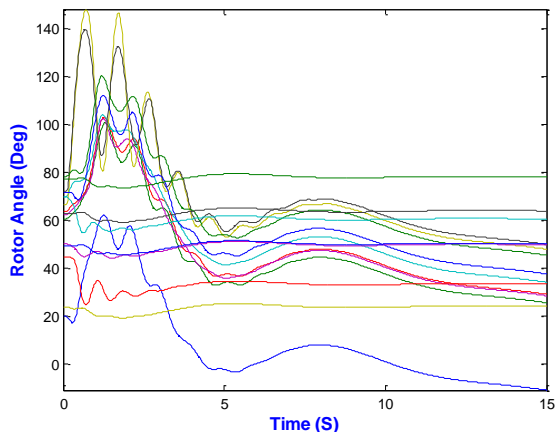

Fig. 3. Rotor angles after applying islanding for 3-phase bolted fault at bus 22, IT = 0.3 S, and ISI = 0.4194.

For the case of applying the islanding scheme with islanding time larger than the CIT, islanding scheme is applied on the previous case with islanding time of 0.8 seconds, which means that the ISI is -0.3541. This value of ISI is less than zero and the islanding scheme will not be able to save the whole system. This can be seen from Fig. 5 and Fig. 6, where the generators G53 to G61 lose their synchronism, while the rest of the system retains its stability. In other words, we lost the island with the fault inside it, but still defensive islanding could save the rest of the system from losing its stability. This shows the importance of calculating and specifying both terms CIT, and ISI, because this will give the power system operators a clear idea about the timing of applying the defensive islanding scheme.

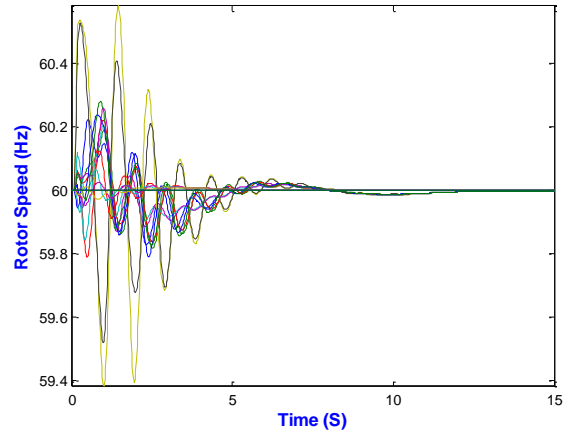

Fig. 4. Rotor speed after applying islanding for 3-phase bolted fault at bus 22, IT = 0.3 s, and ISI = 0.4194.

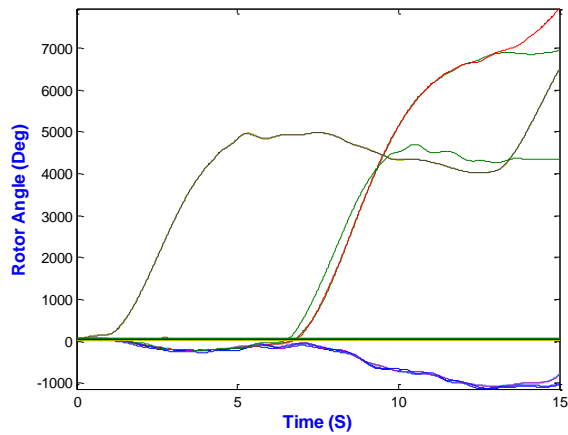

Fig. 5. Rotor angles after applying islanding for 3-phase bolted fault at bus 22, IT = 0.8 s, and ISI = -0.3541.

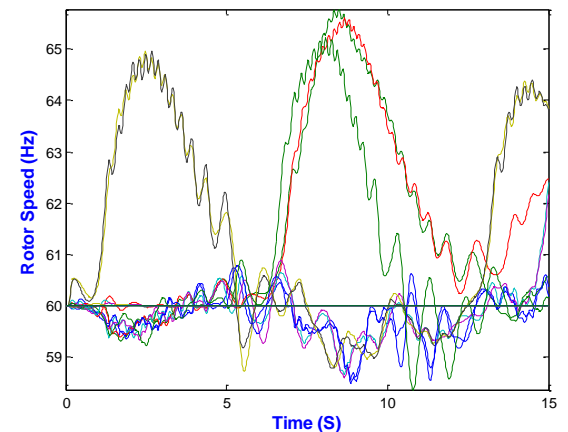

Fig. 6. Rotor speeds after applying islanding for 3-phase bolted fault at bus 22, IT = 0.8 s, and ISI = -0.3541.

5. Conclusion

Defensive islanding is considered as the last resort for the power system operators when the power system is inevitably heading towards uncontrolled separation with losing synchronism

and possible blackout. In this paper, a security assessment for defensive islanding strategy is effectively done by means of calculating the critical islanding time. This security index can be used by the power system operators to determine how much the system will be secure for different islanding times, and to specify when to island for a given islanding strategy. For the cases with small critical islanding time, the power system operators must apply the islanding scheme as soon as possible while, for the other cases, the operators may have a chance to apply other corrective control methods with a lesser cost.

6. Acknowledgment

This work is supported by The Scientific and Technical Research Council of Turkey (TUBITAK) project no. 114E157.

7. References

- [1] H. You, V. Vittal, and Z. Yang, "Self-Healing in Power Systems: An approach using islanding and rate of frequency decline based load shedding," *IEEE Transactions on Power Systems*, vol. 18, no. 1, pp. 174–181, Feb. 2003.
- [2] H. You, V. Vittal, and X. Wang, "Slow Coherency-Based Islanding," *IEEE Transactions on Power Systems*, vol. 19, no. 1, pp. 483–491, Feb 2004.
- [3] H. D. Chiang, "Direct Methods for Stability Analysis of Electric Power Systems," *John Wiley & Sons, Inc., Publication*, New Jersey, 2011.
- [4] B. Yang, V. Vittal, and G.T. Heydt, "Slow Coherency based Controlled Islanding – A demonstration of the approach on August 14, 2003 blackout scenario," *IEEE Transactions on Power Systems.*, vol. 21, no. 4, pp. 1840–1847, Nov 2006.
- [5] N. Senroy, G. T. Heydt, and V. Vittal, "Decision Tree Assisted Controlled Islanding," *IEEE Transactions on Power Systems*, vol. 21, no. 4, pp. 1790–1797, Nov. 2006.
- [6] N. Senroy, G. T. Heydt, "Timing of a Controlled Islanding Strategy," *IEEE PES Transmission and Distribution Conference and Exhibition*, Dallas, 2006, pp. 1460–1466.
- [7] H. Chow, "Time-Scale Modeling of Dynamic Network with Applications to Power Systems," *New York: Springer-Verlag*, 1982, vol. 46, Lecture Notes in Control and Information Sciences.
- [8] G. Xu, V. Vittal, A. Mekin, and J. E. Thalmann, "Controlled Islanding Demonstrations on the WECC System," *IEEE Transactions on Power Systems*, vol. 26, no. 1, pp. 334–343, Feb. 2011.
- [9] G. Rogers, "Power System Oscillations," *The Kluwer International Series in Engineering and Computer Science*, Netherlands, 2000.
- [10] H. Chow, J. Cullum, and R. A. Willoughby, "A Sparsity-Based Technique for identifying Slow-Coherent Areas in Large Power Systems," *IEEE Transactions on Power Apparatus and Systems*, vol. PAS_103, no. 3, pp. 463–473, March 1984.
- [11] M. Mahdi, I. Genc, "Defensive Islanding Using Self-Organizing Maps Neural Networks And Hierarchical Clustering," *PowerTech, 2015 IEEE Conference*, Eindhoven, 2015.
- [12] DSATools™, Dynamic Security Assessment Software Package, 2014. <http://www.dsatools.com> .