

# A SINGLE PHASE SIX-SWITCH INVERTER WITH TWO FIX AND VARIABLE OUTPUT VOLTAGES

Khalil Gorgani Firouzjah<sup>1</sup> Shokrollah Bahrami Samani<sup>1</sup> Mohammad Bagher Sharifian<sup>2</sup>  
Taraneh Herizchi<sup>2</sup>

[kgorgani@stu.nit.ac.ir](mailto:kgorgani@stu.nit.ac.ir) [shsamani@gmail.com](mailto:shsamani@gmail.com) [sharifian@tabrizu.ac.ir](mailto:sharifian@tabrizu.ac.ir) [taraneh\\_herizchi@yahoo.com](mailto:taraneh_herizchi@yahoo.com)

1: Mazandaran University, Faculty of Electrical & Computer Engineering, Babol, Mazandaran, Iran

2: Tabriz University, Faculty of Electrical & Computer Engineering, Tabriz, Tabriz, Iran

*Key words: THD, Six-Switch Inverter, Voltage controller, current controller*

## ABSTRACT

Recent years, a single phase six-switch inverter is introduced as a new DC-AC power conversion converter. To achieve an AC sinusoidal output voltage, a proper switching sequence is produced by voltage and current controllers in two differential and common modes. This paper presents optimal values for voltage and current controllers to achieve a desired AC output voltage with low THD. Different load conditions are tested with these optimal values. The theoretical analysis and MATLAB simulation results are presented to verify this method.

## I. INTRODUCTION

In the past, many sophisticated control techniques has been proposed to deal with the aforementioned general control problems [1-6]. The methods developed in References [1] and [2] can lead to load insensitive voltage regulating control performance, but it seems that they are not suitable for handling nonlinear loads. In Reference [3], a new control technique called sampling a head preview control with on-line parameter estimation is developed to produce low harmonic and fast transient response sinusoidal voltage. To deal with the problems caused by nonlinear loads, Kawamura and Yokoyama proposed some real-time digital feedback control approaches in [4]. All these approaches are easily realized in a one chip microcomputer with flexibility in changing algorithms. On the other hand, Vokosavic et al. have also developed a switching algorithm using output-filter state feedback to improve the waveform of inverter voltage and also to reduce its output impedance. It is known that the feed forward control can be augmented to the feedback control to yield better control performance. This concept has been applied to the voltage control of an uninterruptible power supply (UPS) in Reference [6] to yield extremely good dynamic voltage regulating control performance, even if the load is nonlinear.

In this paper a single phase six-switch voltage source inverter with optimized voltage and current controllers is

used to produce a sinusoidal AC form voltage with higher magnitude and low total harmonic distortion (THD). By optimization of inverter's controller values, proposed inverter has a proper dynamic response and very low THD with different load conditions.

## II. TOPOLOGY OF A SINGLE PHASE SIX-SWITCH INVERTER

Controllable variant AC voltage sources are needed in small industries, laboratories; Single phase six-switch inverter, AC output filters, controllers and proper switching scheme are used to prepare both 220 volts and a Controllable variant AC voltage source [3]. A DC voltage is applied to a single phase six-switch inverter and then converted to an AC sinusoidal form by the use of an L-C filter. Fig.1 shows the general structure of the proposed DC to AC power conversion system which includes many blocks such as: a single phase six-switch inverter, L-C filter, differential and common mode controller and a bipolar SPWM switching scheme controller.

### A. Single Phase Six-Switch Inverter

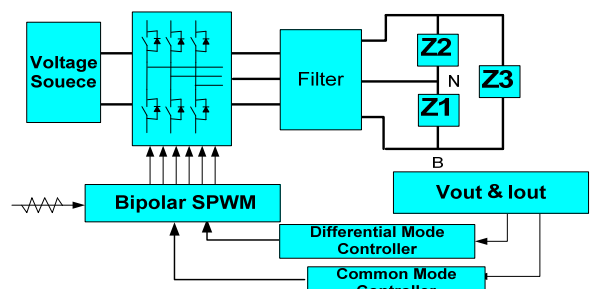

Fig. 1. General structure of the proposed DC to AC power conversion system

According to Fig.1, the boosted DC voltage is converted to a sinusoidal form by a single phase six-switch inverter. This topology is the same as the three phase six-switch inverter but in this topology, middle phase leg is connected to the ground and two other

outputs produce 220 volts and Controllable variant voltage between zero and 220 volt. To achieve a proper output voltage, a controller must be designed based on bipolar SPWM switching technique. This controller includes two parts: (a) differential mode controller that switches legs 1 and 3 to produce a 220 volts sinusoidal AC voltage. (b) Common mode controller that switches middle phase leg to produce Controllable variant voltage [5]. Fig.2 shows the circuit topology of a single phase six-switch inverter and its controller.

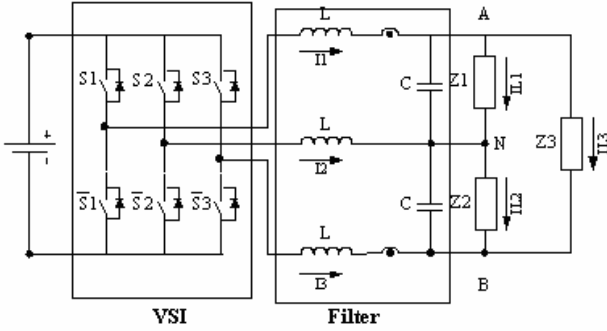

Fig 2. Configuration of a single phase voltage source six-switch inverter

By the use of loop and node analysis in this topology, desired equations for system modelling are achieved.  $S_i$  for  $i=1, 2, 3$  are switching functions of three legs. Due to bipolar PWM switching scheme, there would be

$$S_1 = \bar{S}_3 \Rightarrow S_1 + S_3 = 1 \quad (1)$$

By the use of these equations, differential and common mode controllers can be achieved.

### B. Differential mode controller

A differential mode controller is used to achieve a 220 volts output AC voltage. This controller produces the control signal,  $V_{con1}$ , to compare with triangular wave. The equations for differential mode voltage and current controller are:

$$L_d \frac{dI_d}{dt} = K_{PWM} V_{con1} - V_d \quad (2)$$

$$C \frac{dV_d}{dt} = I_d - I_{Ld} \quad (3)$$

Control signal in differential mode is:

$$V_{con1} = k_d (i_d^* - i_d) + V_d + G_{fd} i_d^* \quad (4)$$

Fig.3 shows the block diagram of differential mode controller by means of voltage and current controllers. In this block diagram  $k_v$  is voltage sensor,  $k_s$  is current sensor,  $k_{PWM}$  is PWM modulator gain and  $G_{fd}$  is main feed forward controller (voltage feedback fault compensator).

### C. Common mode controller

A common mode controller is used to achieve Controllable variant and controllable output voltage. This controller must produce any desired sinusoidal output

voltage between Zero and 220 volts independent of load variations. This controller switches the middle leg.

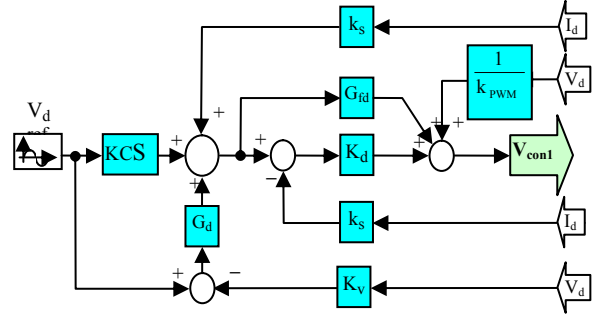

Fig 3. differential mode controller

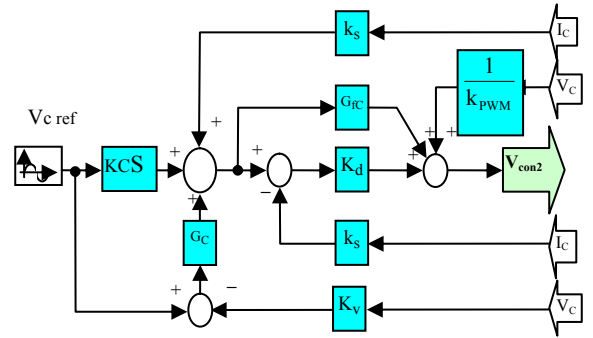

Fig 4. Common mode controller

Voltage and current controllers in common mode are as follows:

$$L_c \frac{dI_c}{dt} = k_{PWM} V_{con2} - V_c \quad (5)$$

$$C \frac{dV_c}{dt} = I_c - I_{Lc} \quad (6)$$

The control signal in common mode is:

$$V_{con2} = k_c (i_c^* - i_c) + V_c + G_{fc} i_c^* \quad (7)$$

Fig.4 shows the block diagram of the common mode controller with voltage and current controller.

### D. Optimization of the voltage & current controllers

To achieve a sinusoidal output voltage,  $V_d$  and  $V_c$  must track  $V_d^*$  and  $V_c^*$ , respectively. Regarding to block diagrams in Fig.3 and Fig.4,  $K$  is determined as  $(k_s/k_v) \times CF$  where  $CF$  is the correction factor for achieve optimal values of controllers and in this case there would be  $\frac{V_d}{V_d^*} = 1$ ,  $\frac{V_c}{V_c^*} = 1$  which means load variations on

output voltage would be eliminated and output voltage is achieved as sinusoidal form. Considering to significance of  $K_s$  and  $K_v$ , in sampling of output current and voltage to precise tracking of  $V_d^*$  by  $V_d$  and  $V_c^*$  by  $V_c$ , determination of optimal value for these two parameters is needed. For this purpose Total Harmonic Distortion and rms value of output voltage are calculated versus variations of  $K_s$  and  $K_v$ .

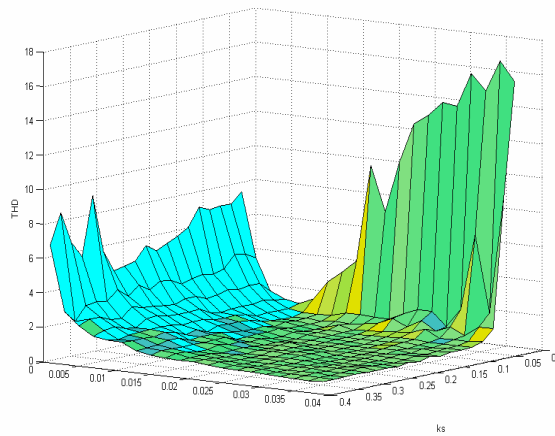

Fig 5. THD of output voltage versus variation of  $K_s$  and  $K_v$

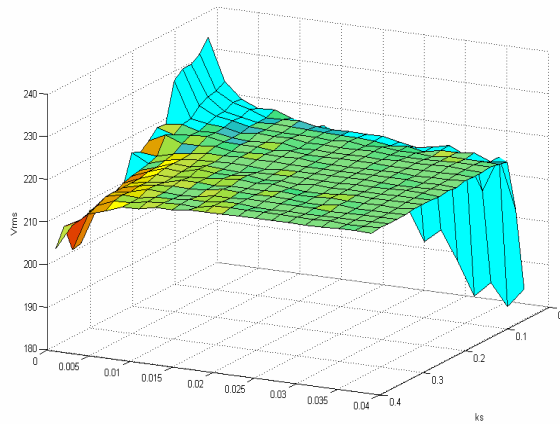

Fig 6. Rms value of output voltage versus variation of  $K_s$  and  $K_v$

Fig.5 and Fig.6 show the variations of THD and rms value of output voltage versus variations of  $K_s$  and  $K_v$  respectively. Regarding to Fig.5, THD of output voltage for  $0.01 < K_s < 0.04$  and  $0.1 < K_v < 0.4$  is less than 2%.

Also in this range, rms value of output voltage is near than 220 volts. Table 1 shows the values of  $K_s$  and  $K_v$  in searching for optimal point or value to achieve low THD,  $V_{rms}=220$  volts and both of them, respectively Based on MATLAB simulation results. Fig.7 and 8 show the variations of CF versus THD and  $V_{rms}$  respectively. According to these figures the best optimal value of CF is 1.2 with  $V_{rms}=220$  volts and negligible THD. Regarding to Tab.1, by choosing prepares  $K_s$  and  $K_v$  in the determined range, the output voltage with low THD and 220volts rms value would be achieved.

Table 1. optimal values of  $K_s$  and  $K_v$

kv	ks	Vrms	THD	Search for
0.037	0.4	217.7	0.27%	Minimum THD
0.007	0.04	220	1.37%	$V_{rms}=220$
0.039	0.26	218.2	0.314%	Minimum THD & $V_{rms}=220$

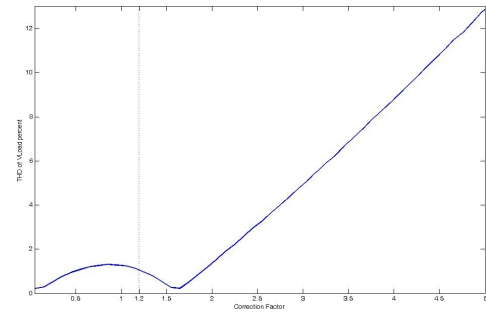

Fig.7. CF for THD

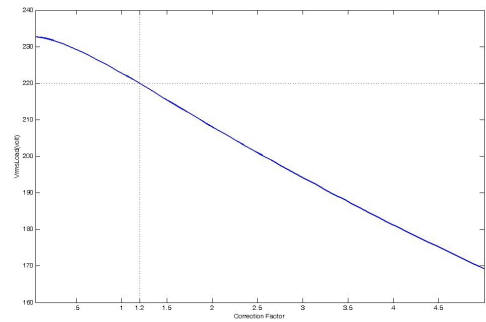

Fig.8. CF for  $V_{rms}$

### III. SIMULATION RESULT

In this paper a simulation model is presented based on optimized controllers as shown in Fig.3 and 4. Table 2 shows the simulation parameters based on the topology of Fig.2. MATLAB simulation results show the capability of optimized controllers to control the switching sequences of the proposed topology. Simulations are carried out in the following sections:

#### A. Single phase Six-switch inverter with an ideal constant dc voltage source

In this section, a single phase six switch inverter with an ideal constant 330 volts dc voltage source is investigated. Fig.9 shows the output voltage after filtering. As shown in Fig.9 a 220 volts AC voltage across  $Z_3$  and two equal voltage levels across the  $Z_1$  and  $Z_2$  are produced. Note that with changing  $V_c^*$ , it is possible to change the voltages across  $Z_1$  and  $Z_2$  between Zero and 220 volts (which sum of these two voltage are 220 volts).

Fig.10 shows the inverter output voltage that a 220 volts AC voltages across  $Z_3$  and two unequal AC voltages (sum of these two voltages are 220 volts) across  $Z_1$  and  $Z_2$  are produced.

#### B. Single phase six switch inverter with variant DC voltage source

Fig.11 shows the inverter output voltage in variant load condition. A variant dc voltage source (e.g. a fuel cell model) is used instead of constant DC voltage source. In this topology, the optimized controllers can produce proper switching signals for single phase six-switch

inverter to achieve an AC sinusoidal form output voltage  $Z_3$  and also two AC voltages are produced across  $Z_1$  and  $Z_2$  which their value can change with  $V_c^*$ . To test the capability of proposed topology variations are occurred at  $t=0.025$ sec and  $t=0.045$  sec.

Table 2. Simulation parameters

$F_c = 10 \text{ KHz}$	$\hat{V}_t = 5$
$V_d^* = kv \times V_{dc} = 3.3 \sin(\omega t)$	$V_d^* = 0$
$V_{dc} = 330 \text{ volt}$	$f = 50 \text{ Hz}$
$k_{PWM} = 330/5 = 66$	$K = ks/kv = 6.66$
$kv = 0.039$	$ks = 0.26$
$Gfd = 5$	$Gfc = 5$
$C_{Filter} = 66 \mu\text{F}$	$L_{Filter} = 2 \text{ mH}$
$Z1 = 10 \Omega$	$Z2 = 30 \Omega$
$Z3 = 40 \Omega \ \& \ 30 \text{ mH}$	

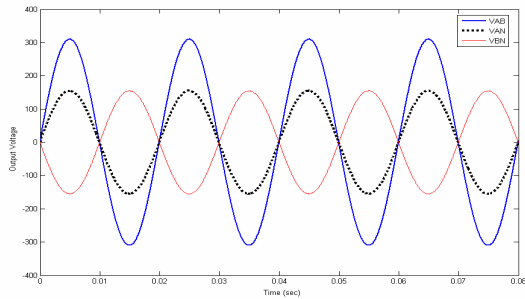

Fig 9. inverter output voltage and two equal voltages

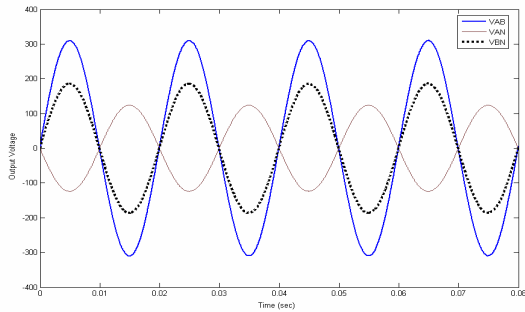

Fig 10. output voltages: a 220 volts voltage and two unequal voltages

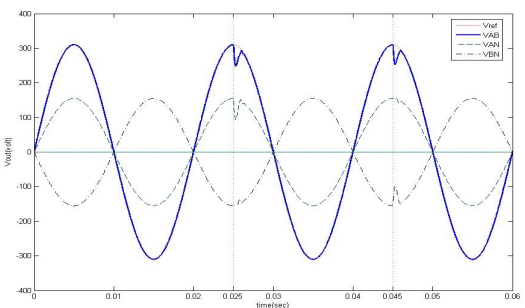

Fig 11. output voltage considering Fuel Cell model as DC voltage source

To test the capability of voltage and current controllers, a  $9.43 \Omega$  inductor is connected in parallel with load at  $t=0.025$  sec and disconnected from the load at  $0.065$  sec. Fig.12 shows the inverter output voltage with load variations at  $t=0.025$  sec and  $t=0.065$  sec.

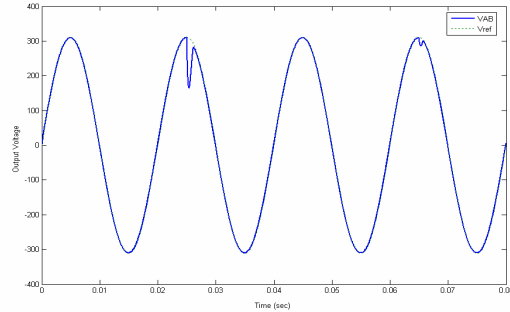

Fig 12. inverter output voltage with load variations at  $t=0.025$  sec and  $t=0.065$  sec

### C. Single phase six switch inverter with variant DC voltage source and random load variation

Fig.13 and Fig.14 show the harmonic spectrum of inverter output voltage after and before L-C filter with random load variations. For this purpose a random load is connected in parallel with  $Z_3$ , five times in a cycle. As shown in the following figures, the THD of output voltage is very low and negligible.

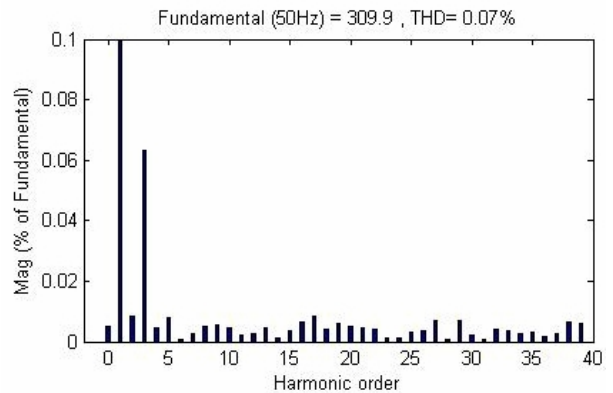

Fig 13. harmonic spectrum of output voltage after filter with constant dc voltage source

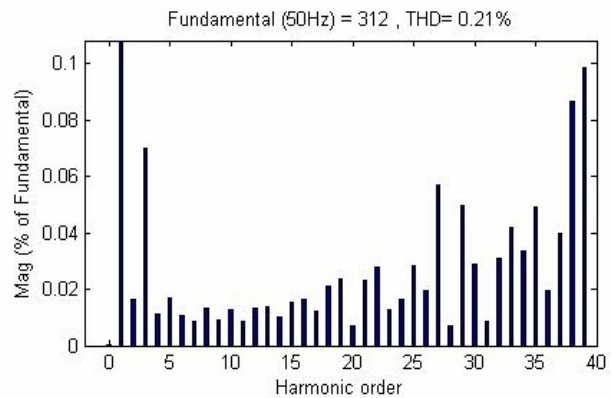

Fig 14. harmonic spectrum of output voltage before filter with constant dc voltage source

## V. CONCLUSION

In this paper the topology of a single phase six-switch inverter has been presented. The above mentioned inverter has used current and voltage controller in common and differential modes for converting output power with load variation. Also, determination of optimal values for these controllers is presented. One of the advantages of this system is reducing THD of output voltage to less than 1% and the rapid retrieving potentiality of voltages to sinusoidal mode after the sudden variation of load and high reliability. By the use of proposed method, this topology can be used in every system with variant voltage source such as fuel cell applications in small distributed generation system. Simulation results with MATLAB reflect the potentiality of this controller for the application in six-switch inverter.

## REFERENCES

1. LIAW, C.M., CHEN, T.H., CHIANG, S.J., LEE, C.M. "Small battery energy storage system", IEE Proc. B, 1993, 140, (1), pp. 7-17.
2. DIVAN, D.M., HABERTLER, T.G., and LIPO, T.A.: "PWM techniques for voltage source inverters". IEEE Power Electronics Specialist Conference Record, 1990, tutorial notes.
3. KAWAMURA, A., and HOFT, R.: "Dead beat control of PWM inverter for sinusoidal output waveform syntheses". IEEE Power Electronics Specialist Conference Record, 1985, pp. 28-36.
4. KAWAMURA, A.: "Comparison of five different approaches for real time digital feedback control of PWM inverters". IEEE Industry Applications Society Annual meeting, 1990, pp. 1005-1011.
5. VUKOSAVIC, S, PERIC, L., LEVI, E., and VUCKOVIC, V. "Reduction of the output impedance of PWM inverters for uninterruptible power supply". IEEE Power Electronics Specialist Conference Record, 1990, pp. 757-762
6. DIVAN, D.M.: "A new topology for single phase UPS system". IEEE Industry Applications Society Annual Meeting, 1989, pp. 931-936.
7. Chiang, S.J.; Liaw, C.M. "Single-phase three-wire transformerless inverter". Electric Power Applications, IEE Proceedings-Volume 141, Issue 4, July 1994 Page(s):197 – 205.
8. C. M. Liaw and S. J. Chiang ." Design and Implementation of a Single-phase Three-Wire Transformer less Battery Energy Storage System" IEEE TRANSACTIONS ON INDUSTRIAL ELECTRONICS, VOL. 41, NO. 5, OCTOBER 1994 , pp.540-549.
9. J. F. Chen, L. Y. Chiang, C. L. Chu, Y. L. Lee, "Study and implementation of the single-phase three-wire photovoltaic energy conversion system" in Proc. IEEE International Conference on Power Electronics and Drive Systems, 1999, pp. 692-695.
10. S.J.Chiang, T.S.Lee, J.M.Chang, "Design and implementation three-arm rectifier of a single phase inverter" in IEE Proc.-Electron. Power Appl., Vol. 147, No. 5, September 2000,pp 379-384.
11. MOHAN, N., UNDELAND, T.M., and ROBBINS "Power Electronics: converters, applications and design", (Wiley, 1995).