

Reducing Over-current Relays Operating Times in Adaptive Protection of Distribution Networks Considering DG Penetration

Morteza Farsadi¹, Amin YazdaniNejadi², and Alireza Esmaily nasab²

¹Urmia University, Urmia, Iran

m.farsadi@urmia.ac.ir

²Amirkabir University, Tehran, Iran

Ay.amin@aut.ac.ir, esmaeily.sc@gmail.com

Abstract

The interest on distributed generations in smart distribution systems changed them to the integral part of the distribution networks. However, hosting of the distributed generation cause some problems for the distribution network protection system including performance delaying of traditional protection systems in case of islanding conditions which is because of the decreasing the sensed currents by the relays and false trip of the relays because of missing distributed generations. In this paper, due to overcome on these problems by using of adaptive relays, a protection scheme based on local data and offline calculation will be proposed which will help relays to adapt themselves with new situations and change their settings automatically and cause better performance in fault situations. In addition, these relays have the ability of fault detection and subsequently update their settings in both retrieval-islanded part by the distributed generations and the part, which are connected to the network. This protection scheme added to a test system and then the results comprised with the traditional scheme.

1. Interdiction

One of the main reasons in case of increasing the hosting of distributed generation in distribution systems is the ability to use in Islanding situations, which will improve the reliability of system. Islanding situation occurs in distribution systems when a part of system is disorted from the others but is feeding by the connected distributed generation. This phenomenon can be desirable or undesirable. For example, it can be desirable for retrieval downward parts of the faulted point. However many problems would be solved before islanding, solving the protection coordination which occur after the islanding and system retrieval will be the most important item.

By penetration of distributed generations in distribution systems, the system wouldn't be a radial system the direction of the currents wouldn't be in one orientation, and the systems changed to a double feed system. So the non-directional overcurrent relays replaced by directional ones. [1] The portion of the current feeding by the different distributed generations related to their type. Distributed generations which connected to the system by inverters have the minimum portion in fault current (approx. 1 pu) and it's since their output are controlled by the inverter. Against these DGs, Micro Turbines and synchronous generators have the most portions in the fault current and subsequently have the most effects on protection system. [2] So in this paper all the distributed generations considered as Micro Turbines.

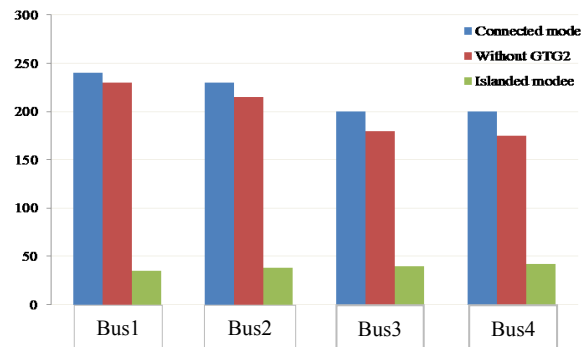

Fig. 1. The difference between short circuit level in two islanding and connected situations.

As showed in figure 1, in Islanding situation system short circuit level deceases and by this reason in the fault situation, relays sense less current in comparison with the connected situation So they will have a delay in tripping and then the fault clearing have subsequent delay. This events cause to loss of more loads, generators and motors. All the generators and motors are equipped with voltage drop relays, which their trip rely on the amount of voltage drop and the time of voltage drop. In addition, if relays sat for the islanding situation in connected situation they may have false tripping.

Adaptive protection systems have this ability to adapt with the different situations of systems and be ready to clear fault in minimum time, which in this case the minimum loss loads gained. There were so much works on this protection scheme in which all of them added units and equipment's for help to the protection system to adapt with all situations of system. In [3] a storage flywheel used due to increasing of micro grid short circuit level that causes the older relays have the ability of simplify fault detection. Also in [4] another method has been proposed. These methods because of two reasons including high cost and low reliability in case of islanding can't be applicable, just when the storage units have the upward short circuit level. In [5] proposed that relays should set for islanding situation and for faults in case of connected situations the system should change to islanded one as soon as possible. In this situation system change to islanded system, so this method cannot be very applicable. In addition, in case in which the amount of loads are more than the distributed generation capacity it shows some detects. By improving the relays and their ability, they use local data to detect the new situation and by using of the settings, which calculated before and added to relays due to manage the new situation. [6] Shows some examples of these methods in distribution system. These methods are ideal for systems with

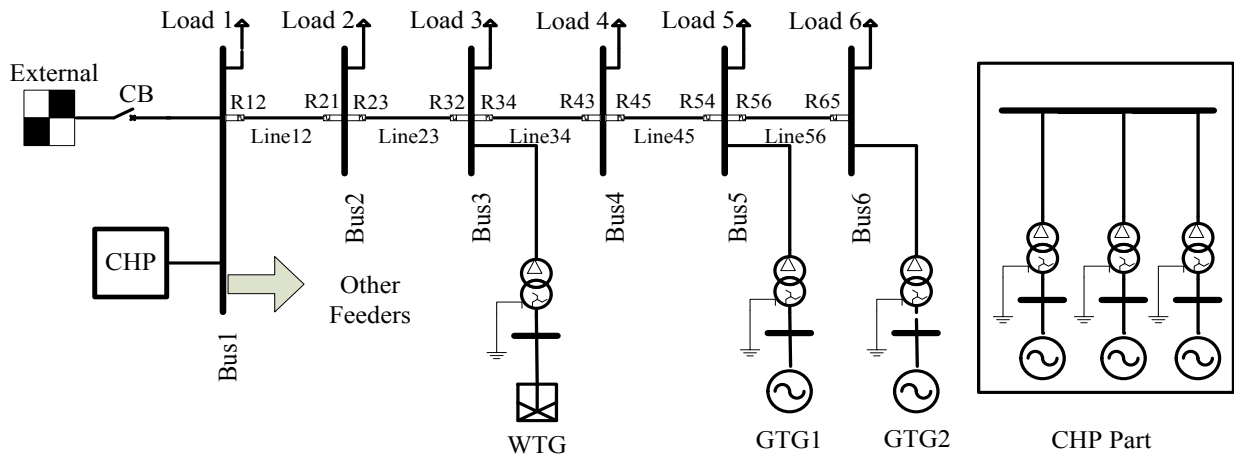

Fig. 2. Test system

low quantity of distributed generations and can consider maximum one entering or exiting of a DG. In [7,8] the optimal settings for two case of islanding and connected used for a protection system equipped by a telecommunication base in which all information sent to the upward and then new settings added to relays. However in islanding situation using of offline calculations can be enough but the retrieval island rely on the fault location. So the number of states is relying on the number of system lines. Data exchange with upward sections increases the sending delay and will increase the probability of data routing. In [9] changing of the sending data protocol used but the directions of data sending increased. So in this paper used a protection system in which all the relays adapt themselves with the new situations and set their settings automatically. So data acquisition will be decreased and with no telecommunication base, it will be applicable. Also in this system all the relays will sat and this cause lower relay operation time. The type of fault in this paper considered three phase. Also the test network presented in section 2 and the proposed method described in section 3. The simulation results discussed in section 4 and the conclusions are presented in section 5.

2. Model of test network

Fig. 2 shows the test network used in this paper which is a part of Denmark network and the lines and loads specification are noted in [10]. This network has CHP, Wind Turbine and 2 Gas Turbines. The CHP includes three Gas Turbines. In this paper because of having more effect on protection relays, all the distributed generation considered as Micro Turbines. CHP connected to the 1th Bus and the others connected to 3th, 5th and 6th and their each capacity is 630 kW. In this paper, relays are digital directional that showed as "R" in Fig. 2 and their numbers are their protection zones. Upward system noted as External.

3. Proposed method

As mentioned before, In Islanding situation the short circuit level will drop. So relays should have the ability of islanding detection and updating the settings. Due to islanding detection, in [9] used of voltage change rate and in [6] used of the frequency change rate. Since in normal conditions, frequency

will vary between 49.9 Hz and 50.1 Hz [10], if frequency passes this limitation-islanding situation occurred and the relay settings should be changed. This method in [10] discussed completely. In islanding condition relays have no need to calculate the settings and these calculations can store in relays that in these situations use from data base. On the other hand, for updating the relay settings after fault, relays should locate the fault to calculate their settings and the other relay settings. Since fault may cause to loss distributed generations and this cause changing in short circuit level. Direct relays by locating the fault inform the others to adapt with the new short circuit level. The main relay also corrects its settings as the first relay changed its settings. For example, if a fault occurs in R45 line, R45 and R54 will trip. Therefore, the network changed to two parts. In this case, the island in right hand which retrieval by GTG1 and GTG2 and the net in left hand which lose two distributed generations and the main feeder relay for over current coordination will be R34. So in left hand part and in Bus 2 R23 locate the fault and inform R21. Because if fault occur in line 12 R21 won't sense the same current and should calculate new settings. In addition, R23 set itself as second rely. In right hand part and in Bus 5, R54 locate the fault and inform it to R45. In this part in addition to the mentioned works should choose a distributed generation as frequency controller. For example, consume that the last one will be frequency controller. So if R65 sense a fault inform the last Bus distributed generation as frequency controller.

3.1. Fault locating and relay designing

The location of the fault by relay known within this process which each relay saves the other relays specifications for two connected and islanded situations. When relay sense more current than its sat current start to consider the time and when the current gained to the less than of sat current they relay consider that the fault cleared and the time will be finished. This time interval (T_m) includes the time of downward rely trip time and the disconnecting time of circuit breaker. For example when a fault occurs on line 56, R34 sense more current in comparison with R12 and this is because of the distributed generation, which connected to Bus 3. Also this current is less than the fault current because of distributed generation which connected to

Bus 5. By supposing $T_m=600\text{ms}$ and if circuit breaker operation time would be 50ms then the relay trip time is equal to 550ms .

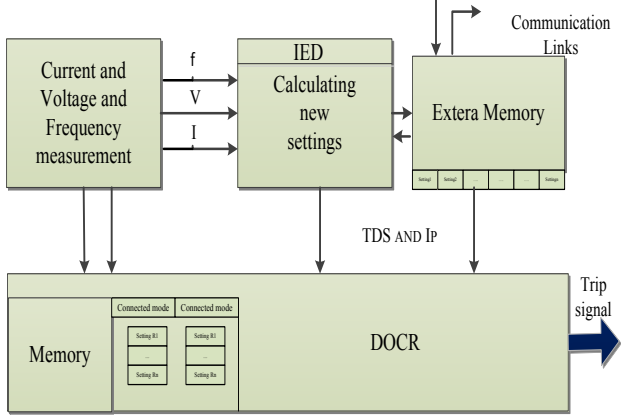

Fig. 3. Adaptive relay block diagram

So R34 according to the sensed current and the calculated time for tripping, introduce the relay which its time-current curve is near to the sensed current and calculated time as tripper relay. For clarifying it, suppose that CTI is equal to 200ms and R34 for the mentioned fault on line 56 operate 940ms later. So if we detract 400ms of it the operation time of R56 will be gained. In this way the relay know that the R56 have been tripped and it has no distributed generation in Bus 6 and also inform it to R32.

With adding IED and memory to the digital relays, the relay will be improved, [15] since they are programmable because of their internal micro controller. [16] Fig. 3 shows this relay block diagram. As shown, the relays send voltage amplitude, frequency (for detecting the islanding), and current amplitude (For detecting during fault) for the mentioned relay. It has a telecommunication link with the upward parts due to inform the other relays changes in feeders or distributed generations. In this way, it can update the relays data base. In addition, there is a connection link among the IED and directional relay that re-set the settings of relays.

3.2. Relays coordination process

Over current Relay operation time definite as inverse function of its current and operate when sense current more than it's sat current. Function of relays defined by two parameters including TDS and Ip. [11] For all relays Ip considered as $1.5 \cdot \text{max load current}$

The operation time for instantaneous relay considered as 50ms for 3 phase fault in nearest feeder to the relay. For the other feeders and faults with resistant relays specification curve modeled as:

$$t = \text{TDS} \frac{A}{\left(\frac{I_{BC}}{I_p}\right)^B - 1} \quad (1)$$

For relays coordination, mostly CTI considered between 200ms and 500ms [13, 14] which in this paper considered 200ms . relay setting for two state of connected and islanding showed in Table 1 and 2. These settings store in relays memory and there is no need to re-calculate in islanding and connecting situations. But for other situations relays should update their settings by the algorithm which shown in Fig 4.

Figures 5 and 6 are for connected situation and show the time straight and inverse curves. Figures 7 and 8 are for islanding situation and show the time straight and inverse curves.

Table 1. Relays setting for connected mode.

Relay	TDS	IP(A)	Instantaneous pickup time
R12	0.2959	350	6280
R23	0.2200	350	5885
R34	0.1695	260	5055
R45	0.1200	112	4710
R56	0.0200	112	4360
R21	0.0100	112	455
R32	0.0580	112	457
R43	0.1000	78	306
R54	0.2100	40	307
R65	0.2562	20	200

Table 2. Relays setting for Islanded mode.

Relay	TDS	IP(A)	Instantaneous pickup time
R12	0.2959	350	6280
R23	0.2200	350	5885
R34	0.1695	260	5055
R45	0.1200	112	4710
R56	0.0200	112	4360
R21	0.0100	112	455
R32	0.0580	112	457
R43	0.1000	78	306
R54	0.2100	40	307
R65	0.2562	20	200

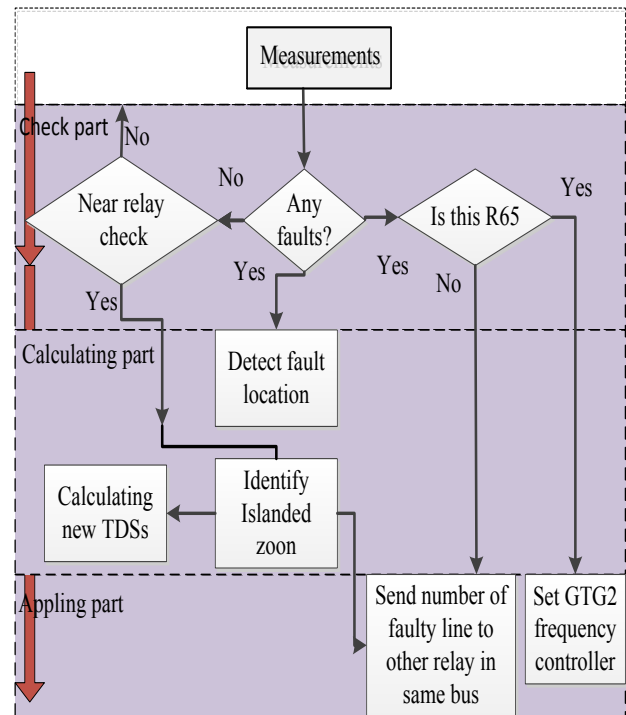

Fig. 3. new settings in new situations calculation process

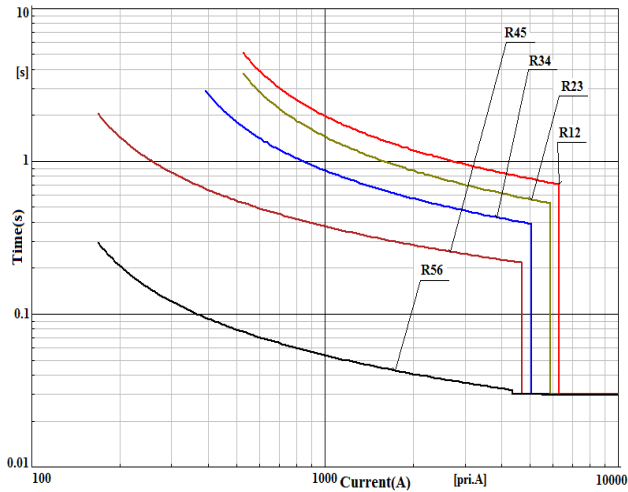

Fig. 5. Relays specification curve in straight direction for connected situation.

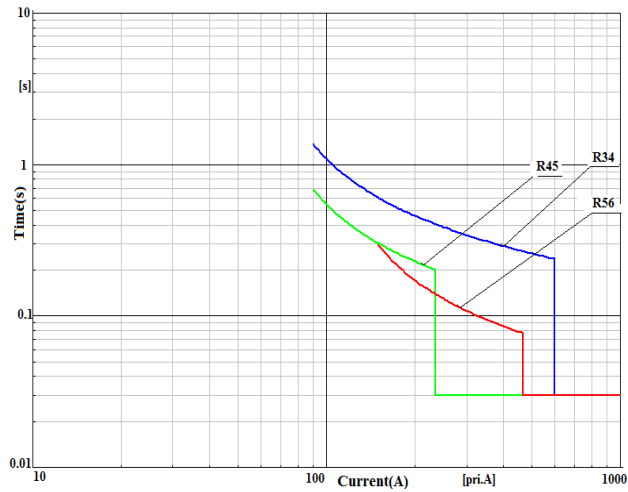

Fig. 6. Relays specification curve in inverse direction for connected situation.

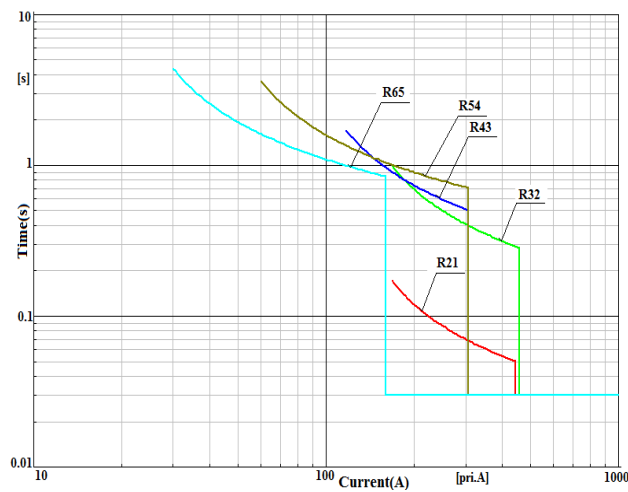

Fig. 7. Relays specification curve in straight direction for islanding situation.

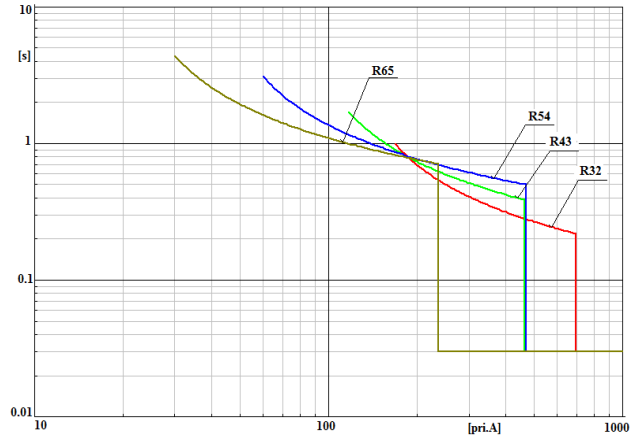

Fig. 8. Relays specification curve in inverse direction for islanding situation.

4. Simulation and simulation results

First, here will discussed about two state that relay settings after islanding not changed and new setting should calculate will be done which help us to comprise the operation times in two cases. Then considered a fault on line 34 and new setting present for left hand relays. In most researches investigation of relay settings limited to the relays which their short circuit level changed. However re-setting of the relays which are connected straight with upward network will cause increasing fault clearing time. So, in this paper for investigation of relay setting after fault occurring, these relay are comprised in 2 cases.

Table 3. Relay operating time for island without re-setting.

Fault location	Tripping time of relays in connected mode (sec)			
	Main	Backup1	Backup2	Backup3
Line12	R12 1.830	R21 0.050	R32 0.266	-
Line23	R23 1.415	R32 0.050	R12 1.894	R43 0.451
Line34	R34 0.849	R23 1.433	R43 0.050	R54 0.645
Line45	R45 0.368	R54 0.050	R34 0.858	R65 0.845
Line56	R56 0.085	R45 0.370	R65 0.843	-

Table 4. Relay operating time for island with re-setting.

Fault location	Tripping time of relays in connected mode (sec)			
	Main	Backup1	Backup2	Backup3
Line12	R12 0.050	R21 0.050	R32 0.265	-
Line23	R23 0.050	R32 0.050	R12 0.850	R43 0.451
Line34	R34 0.050	R23 0.187	R43 0.050	R54 0.645
Line45	R45 0.050	R54 0.050	R34 0.181	R65 0.845
Line56	R56 0.050	R45 0.274	R65 0.050	-

Table 5. Comparison between tables 3 and 4.

Overall time of operation of relays before review	Overall time of operation of relays after review	Percentage Reduction
12.3520s	4.1980s	66%

For investigation of relay operation times, for two case of re-setting and non-re-setting situation, faults are considered in 50% of lines and the results are showed in Table 3 and 4. The total time of these two states and the comparison between them are showed in Table 5. As seen, the total time decreased as 66%. If the comparison were done one by one decreasing the time will be clear. For example, for fault in line 23, R23 in first case operate in 1.415s but in second case operate in 0.050 s.

Table 6. Relay settings for the state of occurring fault on 34 line without revision of direct relays.

Relay	TDS	IP(A)	Instantaneous pickup time
R12	0.2959	350	6280
R23	0.2200	350	5885
R21	0.0200	30	82
R32	0.0619	30	84

Table 7. Relay settings for the state of occurring fault on 34 line with revision of direct relays.

Relay	TDS	IP(A)	Instantaneous pickup time
R12	0.3000	350	6280
R23	0.1300	350	5885
R21	0.0200	30	82
R32	0.0619	30	84

Table 8. Relay operating time for Table 6 settings.

Fault location	Tripping time of relays in connected mode (sec)			
	Main	Backup1	Backup2	Backup3
Line12	R12	R21	R32	-
	0.050	0.050	0.208	-
Line23	R23	R32	R12	-
	0.050	0.050	0.894	-

Table 9. Relay operating time for Table 7 settings.

Fault location	Tripping time of relays in connected mode (sec)			
	Main	Backup1	Backup2	Backup3
Line12	R12	R21	R32	-
	0.050	0.050	0.266	-
Line23	R23	R32	R12	-
	0.05	0.050	0.212	-

Table 10. Comparison between Tables 8 and 9.

Percentage Reduction	Proposed scheme	Conventional scheme
47.77%	0.678s	1.298s

Table 6 show the relay settings when fault occurred on line 34 and revision in settings just for the short circuit level change considered. But in Table 7 this revision occur for all relays. Tables 8 and 9 shows the operation times for settings of Table 6 and 7. In all case fault resistant considered 0.05 ohms. As seen

in Table 10 after revision of the relays, which didn't affect by the change of short circuit level, the operation time of relays may decrease. This investigation just done in left hand of fault. In this case, the total time decreased as approx. 47%.

5. Conclusion

In this paper, investigated the protection problems caused by presence of distributed generations in distribution systems, and the islanding situations and for solving these problems an adaptive protection scheme based on adaptive relays and local data proposed. This protection scheme added to a test system and discussed about results. The result showed that the fault clearing time decreased highly. Also proposed that all the relay settings update since it will have a better improvement.

7. References

- [1] P. P. Bedekar, and S. R. Bhide, "Optimum coordination of directional overcurrent relays using the hybrid GA-NLP approach" in *IEEE Trans. Power Del.*, vol. 26, no. 1, pp. 109–119, Jan. 2011.
- [2] H.R. Baghae, M. Mirsalim, M.J. Sanjari, G.B. Gharehpetian, "Effect of type and interconnection of DG units in the fault current level of distribution networks" in *Center of Excellence in Power Eng., Amirkabir Univ. of Technol.*, Tehran, pp. 313 – 319, September 1-3, 2008.
- [3] H.R. Baghae, "Effect of type and interconnection of DG units in the fault current level of distribution networks" in *Center of Excellence in Power Eng., Amirkabir Univ. of Technol.*, pp. 313 – 319, Tehran, September 1-3, 2008.
- [4] M. Pedrasa and T. Spooner, "A survey of techniques used to control mi-crogrid generation and storage during island operation," in *Proc. Aus-tralian Univ. Power Eng. Conf. (AUPEC)*, Melbourne, Australia, Dec. 10–13, 2006, pp. 1–6.
- [5] H. Nikkhajoei and R. Lasseter, "Microgrid protection," in *Proc. IEEE Power Eng. Soc. Gen. Meet.*, Tampa, FL, Jun. 24–28, 2007, pp. 1–6.
- [6] P. Mahat, Z. Chen, B. Bak-Jensen, C. Leth Bak, "A simple adaptive overcurrent protection of distribution systems with distributed generation" in *IEEE Trans. Smart grid*, vol.2, No. 3, 2011.
- [7] P. P. Bedekar, and S. R. Bhide, "Optimum coordination of directional overcurrent relays using the hybrid GA-NLP approach" in *IEEE Trans. Power Del.*, vol. 26, no. 1, pp. 109–119, Jan. 2011.
- [8] M. M. Eissa, "Protection Technique for Complex Distribution Smart Grid Using Wireless Token Ring Protocol," *IEEE Trans. Smart grid*. vol. 3, no. 3, 2012
- [9] P. Mahat, Z. Chen, and B. Bak-Jensen, "A hybrid islanding detection technique using average rate of voltage change and real power shift," *IEEE Trans. Power Del.*, vol. 24, no. 2, pp. 764–771, 2008.
- [10] P. Mahat, Z. Chen, and B. Bak-Jensen, "A hybrid islanding detection technique using average rate of voltage change and real power shift," *IEEE Trans. Power Del.*, vol. 24, no. 2, pp. 764–771, 2008.
- [11] G. Rockefeller et al., "Adaptive transmission relaying concepts for improved performance," *IEEE Trans. Power Del.*, vol. 3, no. 4, pp. 1446–1458, Oct. 1988.
- [12] R.P. Birla, H.O. Maheshwari, Gupta, "Time-overcurrent relay coordination: a review" in *International Journal Emerging Electrical Power System*, vol. 2, 2005.
- [13] H. A. Abyaneh, M. Al-Dabbagh, S.H. Karegar, H Sadeghi, H.K., R.A.H. Khan, "A new optimal approach for coordination overcurrent relays in interconnected power systems" in *IEEE Transactions on Power Delivery*, pp. 430-435 vol. 18, 2003.

- [14] V. Rashtchi, J. Gholinezhad, , P. Farhang, "Optimal coordination of overcurrent relays using Honey Bee Algorithm" in *International Congress on Ultra Modern Telecommunications and Control Systems and Workshops*, pp. 401-405, 2010.
- [15] F. Razavi, H.A. Abyaneh, M. Al-Dabbagh, R. Mohammadi, H. Torkaman, "A new comprehensive genetic algorithm method for optimal overcurrent relays coordination" *Electric Power Systems Research*, vol. 78, pp. 713-720, 2008.
- [16] M. Singh, B.K. Panigrahi, A.R. Abhyankar, "Optimal overcurrent relay coordination in distribution system" in *International Conference on Energy, Automation and Signal*, pp. 822-827, 2011.