

Novel Flux Switching Axial Field Hybrid Excitation Synchronous Machines, Comparison of Serial and Parallel Models

Emin YILDIRIZ¹, and Güven ÖNBİLGİN²

¹Düzce UNIVERSITY, Faculty of Engineering, Electrical and Electronics Engineering Department, Turkey
eminyildiriz@duzce.edu.tr

²Ondokuz Mayıs UNIVERSITY, Faculty of Engineering, Electrical and Electronics Engineering Department, Turkey
gonbilgi@omu.edu.tr

Abstract

The rotor of the flux switching synchronous machine is simple, these machines have the advantages such as high power density and working at high speeds. When excitation coil is added to the machine, in addition to these properties, air-gap flux density can be easily controlled. Magnetic circuit of the machine can be serial, parallel or independently. Independent circuit design are often complex, therefore it is not taken into consideration in this study. Serial and parallel circuit axial field models are designed at the same dimensions. Flux switching axial field synchronous machine models are compared in terms of magnetic and structure characteristics, power density and efficiency.

1. Introduction

Hybrid Excitation Synchronous Machines (HESM) have been used in wind energy and vehicle systems with flux control ability and compact structures. Power density of the HESM is slightly lower compared to traditional synchronous machines due to the additional excitation coil but it is easy to flux control is an important advantage. According to the space requirements HESM may be axial or radial flux. The studies on axial flux HESM began in 2000s. Most of the axial flux models described in the literature is proposed to use field weakening at the motor mode [1-3]. In reference [2], there are steel poles and permanent magnets on the non-magnetic rotor core in the two stator-one rotor configuration. Toroidal excitation coils are placed between the stator winding and the steel frame of the machine. With embedding the toroidal excitation coil into the stator, suitable structure for all configurations can be obtained (one stator-one rotor, two stator-one rotor, one stator-two rotor or multilayer) [3]. All configurations can be accomplished for flux switching models too [1]. These suggested models can also be used to slightly increased air-gap flux density. In the proposed two rotor-one stator model to support field at the generator mode, there are steel poles and permanent magnets on the ferromagnetic rotor [4]. However, in this case, the magnetic field produced by the excitation coil in the stator complete its path on the ferromagnetic shaft. Therefore, the magnetic path is getting longer. Thus the flux control performance is reduced.

Another classification criteria is the location of the permanent magnets and excitation coils. Both magnetic sources may be in the same location or one of them may be in the stator

and the other one in the rotor. Nowadays, to establish excitation coil in to the moving rotor is not preferred due to using to the brush-ring. In this paper, Flux switching axial field hybrid excitation synchronous models are examined. The permanent magnets and excitation coil of these models are fixed on the stator.

Generally, because of the permanent magnets on the stator core, it is also easy to cool the all coils and the magnets. Since the magnets are on the fixed stator, they are not exposed to centrifugal force and can operate at high speed. The most of the flux switching hybrid excitation models proposed in the literature are radial field. [5-7]. The suggested axial field model have not performed a detailed assessment. Therefore, Flux Switching Axial Field Hybrid Excitation Synchronous Machines (FSAFHESM) is an important model to be examined. In this study, the developed FSAFHESM's with serial and parallel circuits are compared in terms of magnetic properties, air-gap magnetic field control ability, power density and structure features.

2. Flux switching AFHESM

Magnetic flux paths of the permanent magnets and excitation coils can be serial, parallel or independent in hybrid excitation machines. The HESM that have serial magnetic circuits are very straightforward, whereas, the structure of HESM have parallel and independent magnetic circuits are more complex. However, parallel circuit models offer more flexibility in the design process and the risk of demagnetization is low in these models. Therefore, it is worth to investigate both serial and parallel models. The configuration with two rotor-one stator is selected to achieve a high power density. There are armature phase windings on both sides of the stator core. Pole number of stator and rotor are selected 6 and 5, respectively. The model can also be designed at the different pole numbers [8], or different pole ratio.

2.1. Operational principle of AFHESM

Preliminary design features of the developed FSAFHESM's are given in Table 1. 3D model shown in the Figure 1 is the parallel version of the designed FSAFHESM. Permanent magnet volume is determined by the amount of excitation coils. When there is no excitation current in the parallel model, the majority of the magnetic flux completes its loop on the stator yoke so least a portion of the flux passes the air-gap and

switched. If negative excitation current is applied, the total flux passed to the air-gap is further reduced. When the excitation current is positive, the flux supported magnets and the flux generated by the excitation current through the air-gap (Fig. 2).

Table 1. Design specifications

Parameters	Serial	Parallel
Outer stator's diameter (mm)	220	
Inner stator's diameter (mm)	127	
Air gap length (mm)	0.5	
Total machine length (mm)	129	
Phase	3	
Stator poles	6	
Rotor poles	5	
PM values (mm ³)	66	147
PM type	NdFe30	
Iron type	M3624G	
Rated speed (rpm)	600	
Rated power (W)	1200	
Max. current density (A/mm ²)	8	

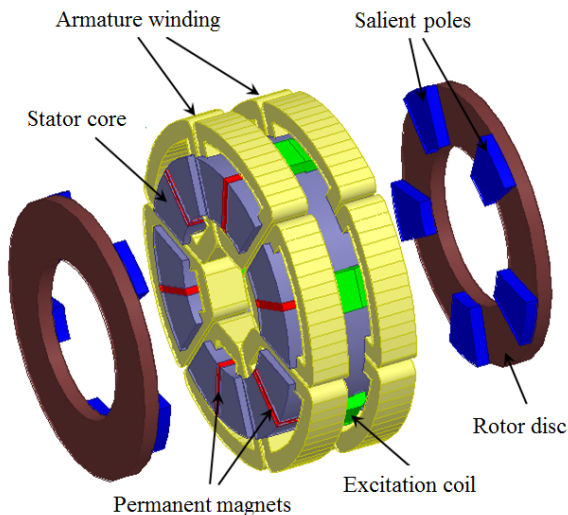

Fig. 1. 3D model of flux switching machine

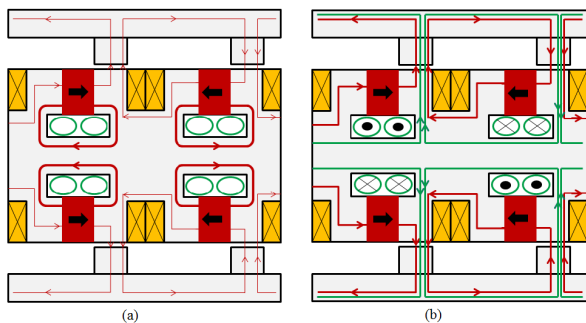

Fig. 2. Magnetic flux paths on the parallel version of the designed FSAFHESM, (Red lines are supported by the magnet, green lines are supported by the excitation coil) (a) Excitation current is zero, (b) Excitation current is positive.

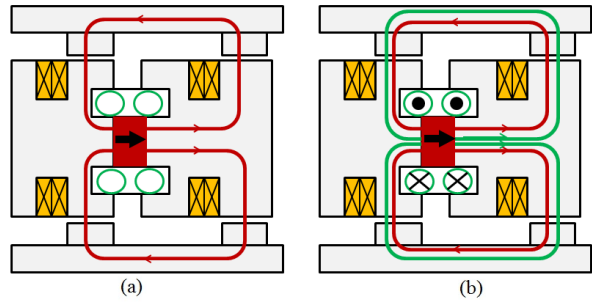

Fig. 3. Magnetic flux paths on the serial version of the designed FSAFHESM, (Red lines are supported by the magnet, green lines are supported by the excitation coil) (a) Excitation current is zero, (b) Excitation current is positive

2.2. Comparison of AFHESM topologies

Serial and parallel versions of the FSAFHESM are compared with the same machine dimensions. Volume of magnet is lower used in the serial version. While different positive current values are applied in the excitation coil in the serial and parallel version, air-gap magnetic flux density changes as shown in Fig. 4. In the serial version, all magnet flux (0,435 T) pass through the air-gap at the excitation current is zero, but in the parallel version the magnetic flux passed to the air-gap is lower (0,281 T). However, the sensitivity of the excitation current is greater in the parallel version. First reason; the magnetic field generated by excitation current is passed via permanent magnets and so the total reluctance of the magnetic circuit increases in the serial version. The second reason; when the excitation current increase, the amount of the flux those path is on the stator yoke is reduced in parallel version. In other words, the excitation current increase, magnet flux passed to the air-gap increase too.

Flux control performance of the parallel version is higher. But there are drawbacks. First is to be more dependent on the excitation current and second is low air-gap flux density when no excitation current.

In serial version, air-gap magnetic flux density can be further increased by growing of the magnet volume. For this purpose, length of the magnet may be bigger. Changing the magnet thickness will increase the reluctance of the magnetic circuit, and so it is not very operative. Increasing of the magnet length means increasing the machine diameter so, when the same magnet dimensions with parallel version are used in the serial version, the dimension of the serial version will be more and the power density will be low. Therefore parallel version is to go one step forward. May be the most important feature of the flux switching machine is that the induced phase voltage waveform is sinusoidal. Fig. 5 shows changed of phase voltage by the excitation current density in the parallel version generator mode at 8 Ω resistive load. Sinusoidal phase voltage waveform does not change at the load.

The excitation current density increase, output power and power density of the parallel version of the model are increasing. In figure 6, the changing of the serial and parallel versions of the generator output power with the excitation current density is given for 8 Ω resistive load. Because the high reluctance of the magnet in the serial version of the model,

while excitation current density increase, the output power does not change too much. Both models were also observed in work at high excitation current density without core saturation. This situation means that the higher copper losses. Parallel version of the model of provides greater air-gap flux densities at lower excitation current so that the efficiency is higher.

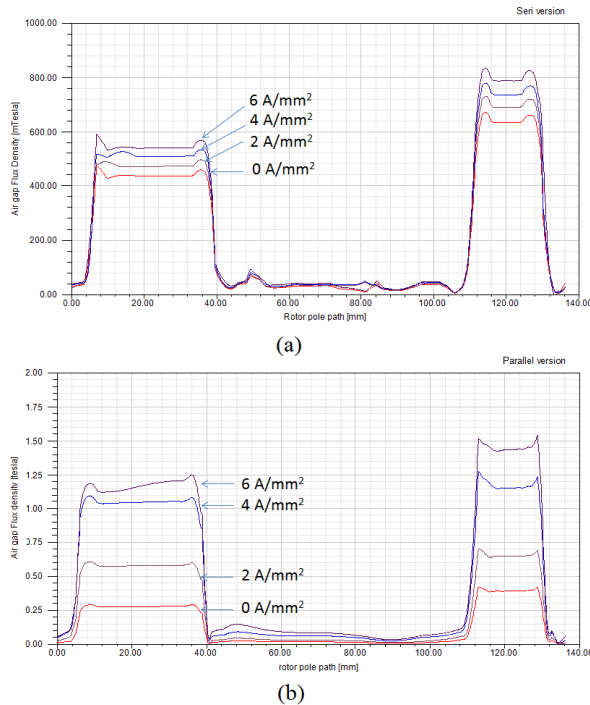

Fig. 4. The change of air-gap flux density at the different excitation current density, (a) Serial version and (b) Parallel version.

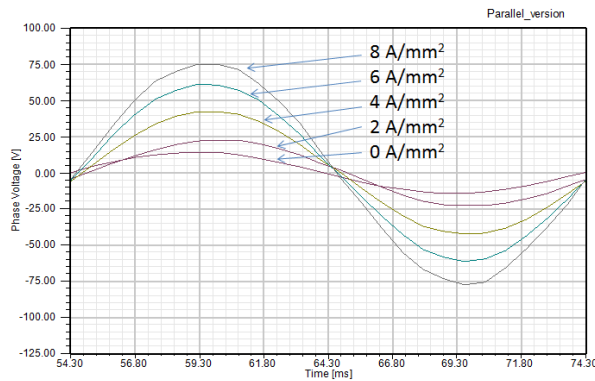

Fig. 5. Phase voltages at different excitation current density

For the parallel model of the FSAFHESM, it is difficult to wound the excitation coils in the stator slots. However, in the serial model it is easier to insert the excitation coils between the stator core modules. Since all the coils and magnets are on the stationary stator core, the cooling is achieved efficiently. However, while the permanent magnet selection, you still need to pay attention to machine operating temperature.

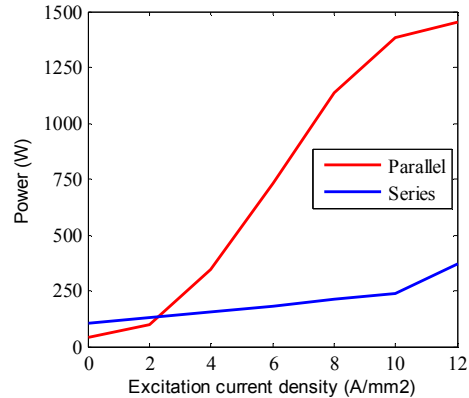

Fig. 6. The change of output power at different excitation current density at 8 Ω resistive load

3. Conclusions

In the parallel version, the air-gap is increased by %400 in the excitation current density about 6A/mm². This supporting ratio is %32 in the serial version. The flux control rate is low in the serial version due to greater total reluctance on the excitation magnetic path. Moreover the parallel version could be used more magnets. Therefore the power density and efficiency of the parallel version is higher than the serial version.

Both serial and parallel structure of the FSAFHESM is not complicated. But parallel version of the model came to the fore with high power density. After the optimization of the parallel model, a small power prototype can be investigated in the feature studies.

4. References

- [1] Liu X., Wang C., Zheng A., "Operation Principle and Topology Structures of Axial Flux-Switching Hybrid Excitation Synchronous Machine", *Journal of International Conference on Electrical Machines and Systems*, 2012, 1, 312-319.
- [2] Hsu J. S., "Direct Control of Air-Gap Flux in Permanent Magnet Machines", *IEEE Transaction on Energy*, 2000, 15, 361-365.
- [3] Lipo T.A., Aydın M., "Field weakening of permanent magnet machine design approaches", *EPE Power Electronics and Motion Control Conference*, 2-4 Eylül, 2004.
- [4] Brown N.L., Haydock L., "New Brushless Synchronous Alternator", *Electric Power Applications. IEEE Proceedings*, 2003, 50, 629-635.
- [5] Hoang E., Lecrivain M., Hlioui S., Gabsi M., "Hybrid excitation permanent magnets synchronous machines optimally designed for hybrid and full electrical vehicle", *International Conference on Power Electronics and ECCE Asia*, 30 Mayıs-3 Haziran, 2011.
- [6] Sulaiman E., Kosaka T., Matsui N., "FEA-Based Design and Parameter Optimization Study of 6-Slot 5-Pole PMFSM with Field Excitation for Hybrid Electric Vehicle", *International Conference on Power and Energy*, 29 Kasım-1 Aralık, 2010.

- [7] Rahimi S.K., Jafar N.A., Sulaiman E., Zakaria S.N. U., “Design Investigation of Hybrid Excitation Flux Switching Machine for High-Speed Electric Vehicles”, *Power and Energy Conversion Symposium*, 12 Mayıs, 2014.
- [8] Sulaiman E., Kosaka T., Matsui N., “Design Optimization of 12Slot–10Pole Hybrid Excitation Flux Switching Synchronous Machine with 0.4kg Permanent Magnet for Hybrid Electric Vehicles”, *International Conference on Power Electronics and ECCE Asia*, 30 Mayıs-3 Haziran, 2011.