

GAIT TRAINER FOR CHILDREN WITH SPASTIC CEREBRAL PALSY

Oğuzhan URHAN

The University of Kocaeli
Electronics & Communication Engineering
urhano@yahoo.com

Aybike DİRİKOL

The University of Kocaeli
Electronics & Communication Engineering
adirikol@kou.edu.tr

Hasan DİNÇER

The University of Kocaeli
EHSAM
hdincer@kou.edu.tr

Key words: Gait Trainer, Cerebral Palsy, CP, Physical Therapy, Force Measurement, Biofeedback Therapy.

Abstract - A device is developed to improve the walking ability of children with Spastic Cerebral Palsy (CP), who have damages to the area of their brain which controls the muscle tone and that causes trouble walking like moving by using their toes instead of applying a steady force to their heels. This device can be adjusted to a correct pressure level to the heels and variations from this value can be displayed by audio and visual signals. By this way, the patient's tendency to walk better may be achieved. Addition to all these valuable signals, the data collected during the walking therapy is stored in a microcontroller and transferred to a computer to provide a database for Physical Therapy (PT) and for children with CP.

Keywords - Gait Trainer, Cerebral Palsy, CP, Physical Therapy, Force Measurement, Biofeedback Therapy.

I. INTRODUCTION

Cerebral Palsy (CP) is a disease which is caused by brain damage. This damage can occur during the period of pregnancy or delivery and after very short time of birth. Shortly Cerebral Palsy can be defined a moving trouble caused by brain damage.

Some of the variety causes are given below [1].

- Prenatal Causes (before birth)

Contagious diseases during pregnancy as measles, German measles, systematic disease as hyper tension, diabetes, heart diseases and blood disease like jaundice, maternal infection, RH factor, metabolic disorders of the mother, accidents cause abdominal injury and lack or absence of prenatal care, and some medicines.

- Perinatal Causes (just before birth including 1 to 4 weeks after birth)

Difficulties during labor, early or late delivery, hard deliveries (vacuum, hard forceps applications, etc.), trauma to the head during labor and delivery, bleeding, poor position of the infant, breech birth, pressure changes due to being delivered too fast or too slow, prematurity and complications at birth.

- Causes of later stage acquired CP

Feverish brain and brain membrane diseases (eclampsia, meningitis), hard jaundice, being poisoned, accident cause injury to the head, vascular problems in the brain, infections of the nervous system, smoke inhalation, near drowning and tumors of the brain.

There are four known types of CP : Spastic, Athetoid, Ataxic, and Mixed. Spastic (hypertonic) CP is statement which appears matters relevant to tight muscles. In Athetoid (dyskinetic, hypotonic, dystonia) CP involuntary movements are present. Ataxic CP happens when the Cerebellum has been damaged, thus causing lack of coordination and sudden movements. Mixed CP happens when more than one type of CP are present in the same person [2].

Spastic CP is the most common type of Cerebral Palsy. It can be subdivided into 5 types :

Quadriplegia : A type of CP when occurs in all four of their limbs-both arms and both legs it is called quadriplegia. Due to the problems of controlling the muscles in their face and upper body, they mostly have problems during talking and eating.

Hemiplegia : Hemiplegia can be defined as the CP which affects one side of the body. Hemi means half, so the right leg and arm or the left leg and arm are affected. The other side of the body works fine. Many children who has hemiplegia can walk and run, although they may look a little awkward or some kind of jerky movement.

Diplegia : Some children have CP only in their legs or more severe in their legs than in their arms. In diplegia, only the two legs are affected. The problem for children with diplegia is using their legs, so walking and running is generally hard for them. Because their upper bodies are usually strong and not affected, they can hold themselves upright and they can use their arms and hands better.

Monoplegia, affecting only one limb and **Triplegia**, affecting three limbs are the two types of Spastic CP that rarely seen.

The purpose of newly developed device named as "Gait Trainer" is to correct the trouble walking by providing feedback information about insufficient force applied to

heels. This device will be very useful for children with Diplegia or Hemiplegia type Spastic CP by helping them to find adequate force should be applied to their heels [3].

Gait Trainer consists of three main parts:

- The heel-part is for measuring the applied force
- The waist-mountable-part is for controlling the device and processing the data coming from heel-part
- The connection cables between heel-part and waist-mountable-part

The force applied to heel of the patient is converted to electrical signals by a load cell. As the measurement result the force applied to hell of the patient is calculated in newton and displayed on an LCD screen by a microcontroller. Also a threshold value can be adjusted by using set-up buttons on the device and an audible and visible signals are produced for higher and a visible signal for lower measurements.

To make the datas, which is obtained when using the device, use by PT teachers, this datas are stored and then transferred via parallel port by an interface software that can be used on the Windows 4.x based operating systems.

By this system a database can developed about children with Spastic CP and their physical therapy programs. This device help children with Spastic CP learn better ways to move and balance.

II. GAIT TRAINER

As mentioned before, the device has three parts. These are; the heel-part, for measuring the applied force, the waist-mountable-part, for controlling the device and comparing the data coming from heel-part to direct the patient and the connection cables carrying the analog signals to data processing circuit located in waist-mountable-part.

The block diagram of “Gait Trainer” is given in Figure 1.

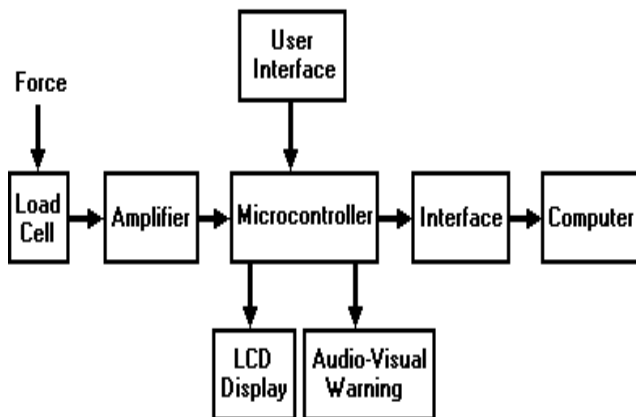

Figure 1. Gait Trainer Block Diagram

III. THE HEEL PART

A basic and common type of load measuring device is the strain gage load cell. Based on the elastic properties of a parent material, the strain is directly proportional to the applied load.

The strain gages are mounted and connected to form a Wheatstone bridge circuit. The basic relationships of : $\text{Stress} = \text{Load}/\text{Area}$ and $\text{Strain} = \text{Stress}/\text{Young's Modulus}$ can be used to determine the strain under different loads.

A typical load cell is given in Figure 2.



Figure 2. Load Cell

When the strain gage is used in a Wheatstone bridge circuit, the change in resistance generates a change in voltage that meter amplifies, digitizes and converts to a known unit for displaying a weight. Load cell as explained above consists of strain gages and a Wheatstone bridge circuit.

In Gait Trainer an EF5-A type 6 kg single point load cell is used and it operates between 3V-15V range [4]. To make the device smaller and portable, 4.5V power supply which will be quite enough for 25 hours of usage is preferred (3 each 1.5V Nickel-Cadmium Battery).

The output voltage of load cell is measured 65mV when no force is applied and 100mV when 6 kg is applied. The signal at the output of load cell is an analog signal and it is directly proportional to the force applied.

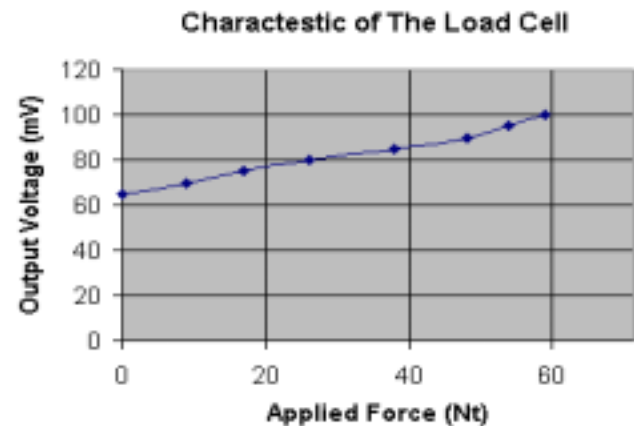

Figure 3. Charactestic of The Load Cell

IV. INSTRUMENTATION AMPLIFIER

Before using the signal which is coming from the load cell in microcontroller stage, it must be amplified to a certain level. Because signal which is coming from heel-part too low for an ADC that would convert analog signals. For this purpose, an instrumentation amplifier AD627 is used.

The schematic of instrumentation amplifier stage is shown below.

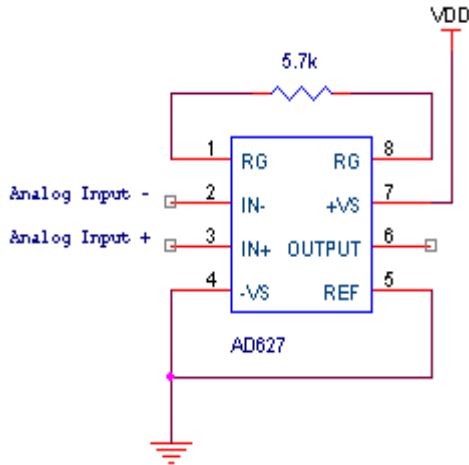

Figure 4. The schematic of instrumentation amplifier stage

Gain equation of instrumentation amplifier stage is [5] :

$$(1) \quad G = 5 + \frac{200k\Omega}{R_G}$$

For ADCs, 40 times amplification will be quite enough. If we calculate R_G value for this amplification level :

$$(2) \quad R_G = \frac{200k\Omega}{G-5} = \frac{200k\Omega}{40-5} = 5.714k\Omega$$

As a result, a voltage between 2.5V to 4V is measured at the output of instrumentation amplifier. This voltage level is enough for ADCs to convert an analog signal to digital signal.

V. MICROCONROLLER STAGE

For controller stage of device an 8 bit architecture CMOS Flash microcontroller PIC16F877 produced by Microchip is used. 10 bit multi-channel ADC, 8K program memory and 33 I/O pins can be listed as some of reasons for choosing this microcontroller.

Some important features of PIC16F877 are listed below [6] :

- High performance RISC CPU
- Up to 8K x 14 words of FLASH program memory
- Up to 368 x 8 bytes of Data Memory (RAM)
- Up to 256 x 8bytes of EEPROM data memory
- 33 I/O pins
- 10-bit multi-channel ADC
- Operating speed: DC – 20MHz clock input
- Interrupt capability (up to 14 sources)
- Programmable code protection
- Low power consumption (typically <2mA)

Microcontroller stage is the most important part of the Gait Trainer. To make signal, which is obtained from heel-part, must be amplified to a certain level by instrumentation amplifier stage. Otherwise conversion results will not be correct.

Tasks, which the microcontroller stage will perform are as follows:

- Converting the analog signal coming from instrumentation amplifier stage to digital.
- Comparing the converted signal with a desired threshold value which was set via control buttons and inform the patient by both audio and visual signals if the force applied is correct or not.
- Calculating the applied force in newtons and show the result on LCD display.
- Storing the data collected.
- Transferring the stored data to a computer.

To perform the tasks listed above, device has six buttons. These are; an ON/OFF switch to turn the device on or off, START button to start sampling, SHOW THRESHOLD button to show the threshold value used at the moment, UP and DOWN buttons to increase or decrease the threshold value in 1 newton steps and SEND button to transfer the stored data to a computer.

When the patient applies a value more than the threshold, a green LED and buzzer give signals to inform the patient that a correct force is applied and when the value is lower than the threshold, a red LED signals. By this way, the patient's tendency to walk better may be achieved.

In addition to warning signals, the exact value applied to heel and calculated in newton by PIC16F877 is indicated on the HD44780 based 2x8 LCD display.

After calculation of values in newton by PIC16F877, it is necessary to store this data in device for later usage of special PT teachers. For this task, 4K portion of 8K program memory of PIC16F877 is assigned. The walking therapy is divided into 1sec intervals and the biggest value applied to heel is recorded. Recording may be adjusted for each force application to load cell (each step on the load cell).

The Gait Trainer circuit is given below in Figure 5.

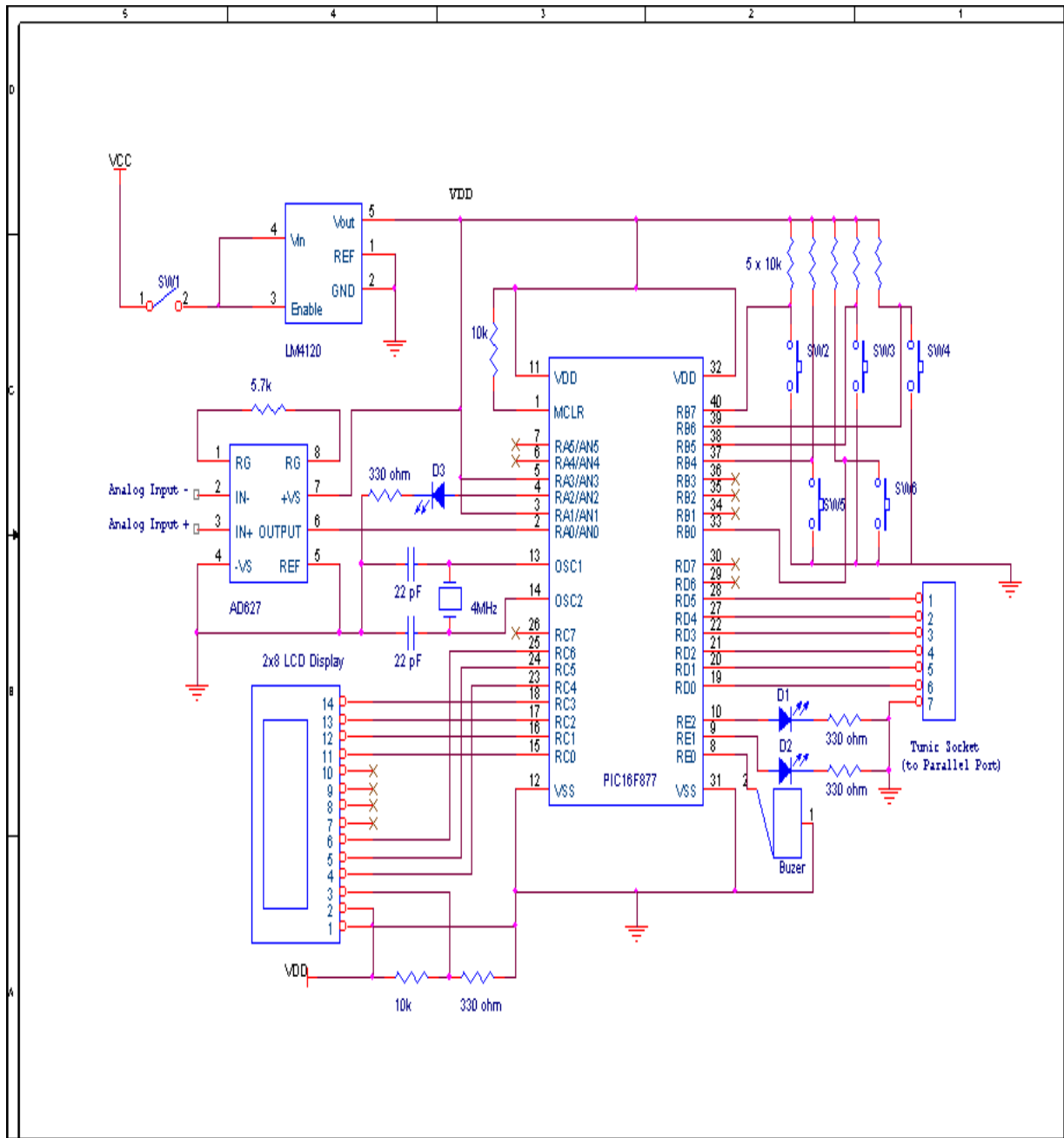

Figure 5. The Gait Trainer Circuit

By recording 1 sec intervals, the 14 words x 4K memory can store information for 2 hours which is quite enough during the walking therapy mostly lasted not more than half an hour.

To be used by special PT teachers as reference, the data stored in program memory of PIC16F877 should be transferred to a computer. By this way, a database can be developed for children with CP.

So, by using this database, improvement process of the therapies can be easily observed.

To transfer the data about the force applied to heel to a computer using Windows 4.x based operating system, an interface software developed in Microsoft Visual C++ 6.0 programming language. In this program, a similar data transfer protocol between printers and computers is used [7].

A window of the program is shown below in Figure 4.

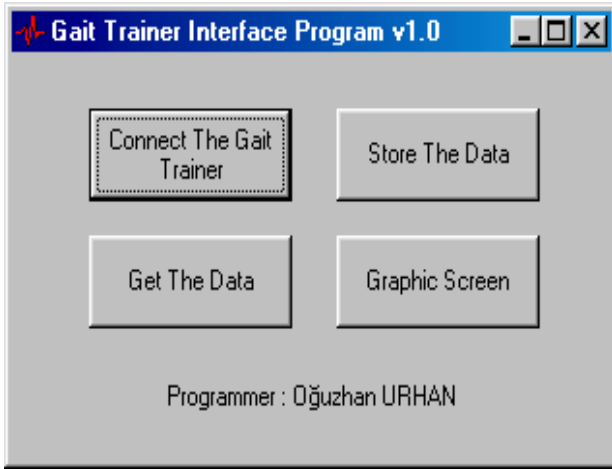

Figure 6. A sample window from interface program

VI. CONCLUSION

Although the medical science is so developed and the causes of CP is known in detail, the illness cannot be completely cured and children will have it all their lives. They often go to different kinds of therapy to improve their motor skills for things like walking, talking and using their hands.

The Gait Trainer is developed to inform the patient if the correct force is applied to heel or not by visual and audio signals.

At the same time, the exact value of the force is indicated in newtons on LCD display. Addition to the warning signals, the data collected during the walking therapy is stored in a micro controller and transferred to a computer to provide a database for Physical Therapy and for children with Cerebral Palsy. By using this data a better walking therapy can be achieved.

REFERENCES

1. Cerebral Palsy Information Central (CPIC) Web Site <http://www.geocities.com/HotSprings/Sauna/4441/CPIC.html>
2. Medical Center , University of Virginia Web Site <http://hsc.virginia.edu/cmctutorials/cp/>
3. O. Urhan, A. Dirikol, H. Diñer, “Çocuklarda Beyin Felci Hastalığı Tedavisi İçin Yürüyüş Eğitimi”, NEU-CEE 2001 Electrical, Electronic & Computer Engineering Symposium, 23-25 May, Lefkoşa TRNC, pp. 67-70
4. HBM Product Catalog , 1999
5. Analog Devices Product Catalog , 2001
6. Microchip Product Catalog , 2000
7. Dr. Haluk Gümüřkaya, “Mikroiřlemciler ve Bilgisayarlar” , Alfa Yayınları , 1999