

Investigating Voltage Stability Problem in the Electrical Power System Using Gravitational Search Algorithms

Ali Oztürk, Salih Tosun, Selman Alkan, Beytullah Bozali

Duzce University Engineering Faculty Dept. of Electrical & Electronics Engineering / 81620 - Duzce, TURKEY
aliozturk@duzce.edu.tr, salihtosun@duzce.edu.tr, selmanalkan@duzce.edu.tr, beytullahbozali@duzce.edu.tr

Abstract

This study aims to utilize the Gravitational Search Algorithm (GSA) to find the optimal values of the proportional integral derivative (PID) controller parameters to control the automatic voltage regulator (AVR). GSA is categorized as a heuristic algorithm. In finding the optimal values, we try to minimize the performance index also called the error in the closed loop control diagram. We observed and compared the three different situations of the error, namely the integrated absolute error (IAE), the integral of squared error (ISE), and the integral time absolute error (ITAE). We, then, employed a conventional Ziegler- Nicolas Method (ZNM) to find the optimal values under the same conditions with GSA. The values obtained through both methods are compared at the end. We show that the proposed method using GSA has a better performance than ZNM in terms of settling time, oscillations and overshoot. We also compared our results with the ones obtained through Genetic Algorithms (GA). Similarly, our method performs better.

1. Introduction

Power systems are categorized as nonlinear systems, and their operating conditions vary over a wide range. Recently problems regarding voltage and frequency stability have become more interesting to the researchers as well to the people in industries. The increased size of generating units, the flowing active and reactive power in the transmission lines, need for the high-speed excitation systems, and the load changes are the main roots for these stability problems [1,2]. Different control methods have been used for AVR such as Fuzzy Logic and PID Controller, etc. [3-5]. In industrial applications, the PID control algorithm is commonly used. To adjust the PID parameters, Ziegler-Nichols method is one of the frequently employed ones [6]. Global optimization techniques like GA and Particle Swarm Algorithm have recently attracted the attention in the field of controller parameters optimization [7]. Usage of AVR in the excitation systems reduces negative damping which yields undamped oscillations. Power system stabilizers (PSS) are used to help to reduce the damping of the oscillations [8]. In order to solve control problems, an AVR system is commonly adopted to the power generation units [9]. Swidenbank and coworkers studied the classical self-tuning control techniques to AVR systems [10]. Similarly, Gaing conducted researches about PSO and GA based self-tuning PID controllers for AVR systems [11]. Maintaining constant frequency in power systems is the key to provide reliable power.

This paper proposes a new method adapting GSA to determine the optimal values for PID controller parameters for AVR to damp power system oscillations. In this study, first PID controller parameters for AVR was tuned using standard techniques such as Ziegler-Nichols and GA methods. Then, same parameters were tuned again with GSA this time. And we compared the results. The effectiveness of the proposed method is supported by the observed simulation results, which show the ability of the proposed GSA in damping oscillations for various load changes.

2. Problem Definition

In the following sections, we first briefly describe the general structures of AVR and PID controllers along with the methods to find the PID parameters. Then, we summarize the Ziegler-Nichols, GA, and GSA methods that we used in our study.

2.1. Single AVR Structure

AVR is an important part of the excitation system used to produce and control the excitation current in power systems [13]. In other words, AVR ensures that the voltage and the reactive power values remain within the limits by regulating the DC current output [14,15].

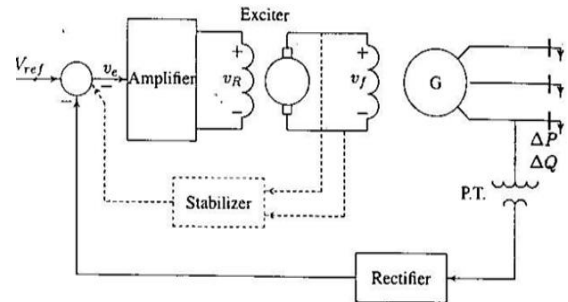

Figure-1 Excitation control system

A typical excitation control system is illustrated in Figure 1. Voltage value in the load buss is reduced over the transformer then rectified. This regulated voltage is compared with the desired voltage (V_{ref}) which yields the error voltage value (V_e). V_e , in turn, is amplified to adjust the reactive power in the generator and to adjust the load buss voltage value [15]. During this regulation processes, some undesired disturbances such as time delays may occur [16, 17]. The role of an AVR is to hold the terminal voltage magnitude of a synchronous generator at a specified level. A simple AVR system comprises four main components, namely amplifier, exciter, generator, and sensor. For mathematical modeling and transfer function of the four components, these components must be linearized, which takes into account the major time constant and ignores the saturation or other nonlinearities. The reasonable transfer function of these

components may be represented, respectively, Amplifier model, Exciter model, Generator model, Sensor model [11]. Figure 2 illustrates the AVR block diagram based on the models [18].

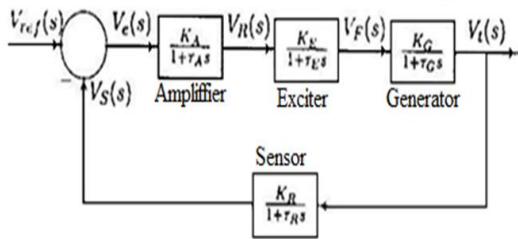

Figure-2 AVR Block Diagram

$$\frac{V_t(s)}{V_{ref}(s)} = \frac{K_A K_E K_G K_R (1 + \tau_R(s))}{(1 + \tau_A(s))(1 + \tau_E(s))(1 + \tau_G(s))(1 + \tau_R(s)) + K_A K_E K_G K_R} \quad (1)$$

Considering the block diagram in figure.2, the system transfer function given in equation 1 was obtained, and its parameters were outlined in Table 1.

Table-1 AVR Parameters for the transfer function in Equation 1

	Gain	Time constant
Amplifier	$K_A=10$	$\tau_A=0.1$
Exciter	$K_E=1$	$\tau_E=0.4$
Generatör	$K_G=1$	$\tau_G=1.0$
Rectifier	$K_R=1$	$\tau_R=0.05$

2.2. PID Controller

The PID controller is used to improve the dynamic response as well as to reduce or eliminate the steady-state error. The derivative controller adds a finite zero to the open-loop plant transfer function and improves the transient response. The integral controller adds a pole at the origin, thus increasing system type by one and reducing the steady-state error due to a step function to zero. The PID controller transfer function given in equation 2 [19]. PID control parameters can be determined by various methods, such as the Zigler-Nicolas Method, Genetic Algorithm and Gravitational Search Algorithm.

Zigler-Nicolas Method: The *I* and *D* coefficients are set to 0. Then, *P* is increased gradually until the system reaches to the oscillation [20]. When the system reached to its first oscillation, *P* value is named K_u [12]. This situation was illustrated in figure 3.

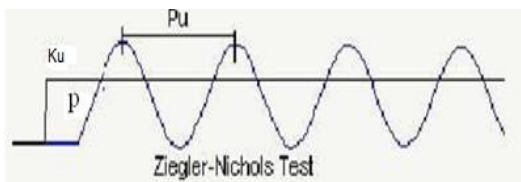

Figure-3 When the system reaches to the oscillation system response

PID control coefficients are obtained through P_u and K_u values entered in table 2.

Table-2 PID Parameters in ZNM

Controller type	K_C	t_r	T_D
P	$K_u/2$	-	-
PI	$K_u/2.2$	$P_u/1.2$	-
PID	$K_u/1.7$	$2/P_u$	$P_u/8$

Genetic Algorithm Method: GA is an optimization method based on the genetic concept. It is a strategy for solving the multi-variable optimization problems which are considered to be difficult by conventional optimization methods [20, 21]. GA starts to run with a lot of possible solution according to the initial population which are randomly prepared. Then, it tries to find optimum solutions by using genetic operators such as selection, crossover and mutation [21]. GA doesn't start the solution with one initial point. It starts to search with several initial points called initial population. So, the best solutions are selected and worst are eliminated. GA starts the search with the generations of the initial population depending on the represented fitness function variables. Initial populations are generated randomly after coding the variables. Each row of the population is called an individual. Fitness function values are calculated for each individual. The Fitness Function (FF), is the difference between the Goal Function (GF) and the penalty function consisting constraints functions. After operated elitism, selection, crossover and mutation, a new population is generated according to the fitness function values. With the evaluation of the previous population, the new population is generated till the number of generation Fitness function values are calculated in each new population. The best resulted ones are paid attention among these values. Until the stopping criteria are obtained, these processes are repeated iteratively. The stopping criteria may be the running time of the algorithm, the number of generation and for fitness functions to give the same best possible values in a specified time. In this study generation size has been used as the stopping criteria

Gravitational Search Algorithm Method: According to Newton's law of gravity, there is a force of gravity between the every object pair in the universe. Objects attract each other by the gravity force. The principle that two particles attract each other with forces directly proportional to the product of their masses divided by the square of the distance between them. This condition is represented by equation 2, where *F* is the force in Newton's law, m_1 and m_2 are the masses of the bodies in kilograms, *G* is the gravitational constant, and *R* is the distance between the bodies in meters. Newton's second law can be expressed as a mathematical formula for the amount of force needed to accelerate an object. The change in acceleration is directly proportional to the magnitude of the force applied to the object and inversely proportional to the mass of the object. This condition is represented by equation 3. Where *a* is acceleration [22-23].

$$F = G \frac{M_1 \cdot M_2}{R^2} \quad (2)$$

$$a = \frac{F}{M} \quad (3)$$

Gravitational Search Algorithm (GSA) is a new optimization algorithm. GSA works on the basis of Newton's law of gravity. GSA proposed by Rashedi et al [24]. GSA can be considered as isolated masses system. This system fits Newton's laws of gravity and motion. In the Newton law of gravity, each mass attracts every other mass with a gravitational force that is defined equation 1. Masses defined to find the best solution in GSA. GSA simulates a set of masses that behave as point masses in an N -dimensional search space. According to this algorithm defined in order, masses are considered as objects. Every object represents a solution of the problem. Heavy masses corresponding to the best solution, they move more slowly than lighter ones. In GSA, position of each mass in search space is a point in space and is taken in account as a solution to the problem. This position was given equation 4. The masses initialize the positions of the N number of masses. Where, x_i^d represents the positions of the i -th mass in the d -th dimension and n is the space dimension, v_i^{d1} also represents the velocity of each mass was given equation 5.

$$X_i = x_i^1, x_i^2, \dots, x_i^d, \dots, x_i^n \quad i=1,2,3, \dots, N \quad (4)$$

$$V_i = v_i^1, v_i^2, \dots, v_i^d, \dots, v_i^n \quad i=1,2,3, \dots, N \quad (5)$$

Taking into account other mass fitness values, each mass fitness values are calculated according to equation 6. Where $M_i(t)$ represent i th mass of t time and $fit_i(t)$ is also fitness value of the i th mass, $best(t)$ and $worst(t)$ fitness of all masses. According to the type of optimization problem, these values changes as minimum or maximum

$$m_i(t) = \frac{fit_i(t) - worst(t)}{best(t) - worst(t)} \quad (6)$$

$$M_i(t) = \frac{m_i(t)}{\sum_{j=1}^N m_j(t)}$$

$$G(t) = G(t_0) * e^{-k * \frac{t}{T}} \quad (7)$$

Equation 7 calculate gravitational constant $G(t)$ in time t . T is number of iterations. $G(t_0)$ initial value of gravitational constant, t also refers to the moment of iteration. F_{ij}^d is a force acting on mass ' i ' from mass ' j ' at d -th dimension and t -th iteration is computed as equation 8, where, $m_{pi}(t)$, $m_{aj}(t)$, active and passive masses respectively, at iteration t $R_{ij}(t)$ is the Euclidian distance between two masses ' i ' and ' j ' at iteration t . ε is a small constant.

$$F_{ij}^d = G(t) \frac{m_{pi}(t) * m_{aj}(t)}{R_{ij}(t) + \varepsilon} (x_j^d(t) - x_i^d(t)) \quad (8)$$

The total force acting on mass i in the dimension d is calculated equation 9 where $rand_j$ is a random number in the interval $[0,1]$. Equation 10, Find the acceleration of mass i in d th dimension

$$F_i^d = \sum_{j=N, j \neq i}^N rand_j * F_{ij}^d(t) \quad (9)$$

$$a_i^d(t) = \frac{F_i^d}{M_i(t)} \quad (10)$$

Velocity and position vectors for each mass i , recalculated for the new iteration according to equation 11 and 12.

$$v_i^d(t+1) = rand_i * v_i^d(t) + a_i^d(t) \quad (11)$$

$$x_i^d(t+1) = rand_i * x(t) + v_i^d(t+1) \quad (12)$$

Using equations between 5-12, position and velocity values for each mass number are calculated repeatedly until it reaches the number of iterations. GSA flowchart was given figure 4.

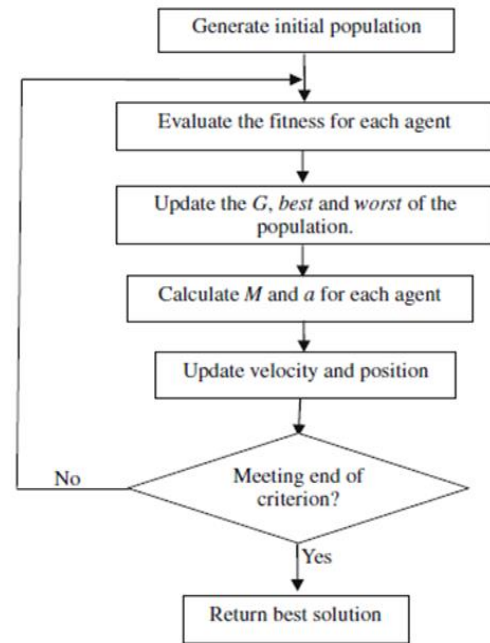

Figure-4 GSA Flowchart

3.Solution

In LFC, it is aimed to keep the system frequency within the limits. AVR amplifies the V_e error signal to keep the terminal voltage values within the limits. As a result, generator field current increases which in turn increases the elector motor force (emf). Terminal voltage is brought to the desired value by rearranging the reactive power values to its new stability point. Oscillations occur within the generator voltage and speed values following the disturbances in the system. AVR are used for dumping those oscillations. As a tool, we used the Matlab/simuling application. In PID controller, the difference between the desired and the measured values is defined as the error. Due to the saturation in the magnetic circuit, this error has the nonlinear characteristic behavior. We first employed ZNM. Then, we used GSA and genetic algorithms categorized as heuristic methods to determine the coefficients in the PID controller. In both ZNM and GSA methods, error is minimized and the PID coefficients in minimizing the error are taken as variables. As a goal function, we used the integrated absolute error (IAE), the integral of squared error (ISE), and the integral time absolute error (ITAE) to find the PID parameters while we

minimize the error values using ZNM, GSA, and GA methods. Setting time for each case is compared and illustrated in tables. We used the AVR given in figure 2 for PID controller application. We aimed to have a stable system using a PID controller. We used ZNM, GSA, and GA to determine the optimum values for the PID parameters

4.Results

We used ZNM, GSA, and GA methods for AVR controller. As a goal function, we used IAE, ISE, and IASE to find the PID parameters while we minimize the error values. Then, those PID parameters are applied and results are given in figure 5-7 and table 3-5.

Table-3 Comparison Results for AVR for the IAE Goal Function

Controller type	Methods	K_p	K_i	K_d	Setting time (second)
AVR	GSA	0.7007	0.4791	0.2603	2
	GA	0.7675	0.5232	0.4416	5.5
	ZN	0.8823	0.4355	0.5825	10

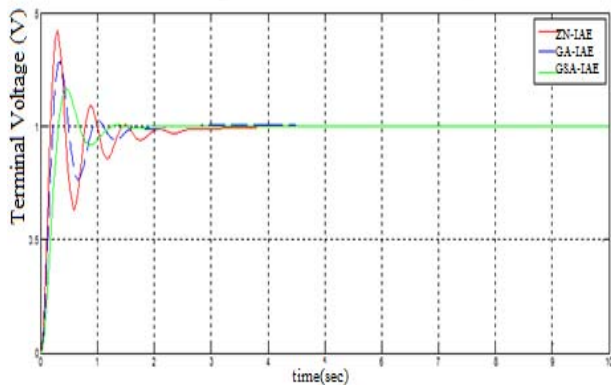

Figure-5 Comparison results for AVR for the IAE goal function

Table-4 Comparison Results for AVR for the ISE Goal Function

AVR Control Methods	K_p	K_i	K_d	Setting time (second)
GSA	0.6330	0.3678	0.3596	3.5
GA	0.6052	0.8289	0.5193	7.2
ZN	0.8823	0.4166	0.6	11

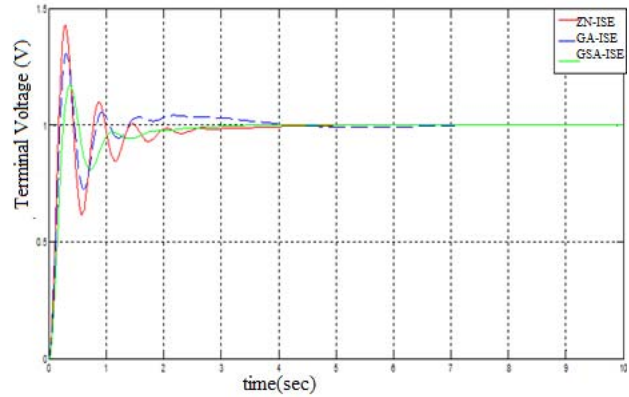

Figure-6 Comparison results for AVR for the ISE goal function

Table-5 Comparison Results for AVR for the IASE Goal Function

AVR Control Methods	K_p	K_i	K_d	Setting time (second)
GSA	0.5488	0.5641	0.1616	3.5
GA	0.4837	0.5133	0.2143	6.5
ZN	0.8823	0.4255	0.5875	12

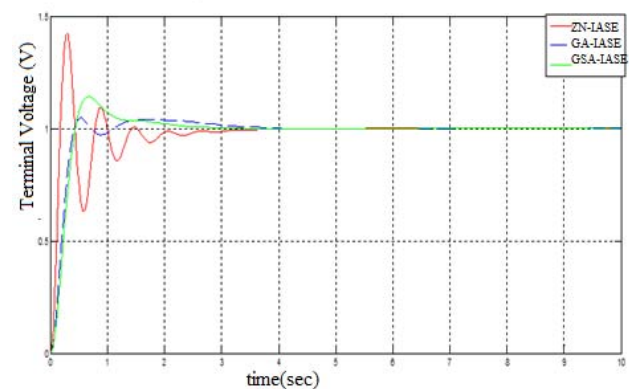

Figure-7 Comparison results for AVR for the IASE goal function

5.Conclusion

In this study, we proposed to use the GSA algorithm to determine the optimum values of PID controller coefficients so that we can determine the best setting time and eliminate the oscillations in AVR controllers. For PID control applications, we adopted Matlab/simulink models and defined transfer functions. First, we used ZNM as a classical method with different cases such as IAE, ISE, and ITAE in AVR. Then, we repeated the study using GSA and GA methods for the same cases and compared the results. We observed that PID parameters obtained through GSA yields shorter setting time and reduced oscillations than those obtained through the classical method. As a result, we conclude that GSA can be used as an alternative method to analyse stability problems in electrical power systems.

6.References

- [1] R.Vikal, and G. Goyal, TCSC Controller Design using Global Optimization for Stability Analysis of Single Machine Infinte-Bus Power System, 15th International Conference on Intelligent System Applications to Power Systems, Curitiba, 2009, pp. 1-7.
- [2] H. Saadat, Power System Analysis , McGraw-Hill , 2002.
- [3] G. Panda, S. Panda, and C. Ardil, Automatic Generation Control of Interconnected Power System with Generation Rate Constraints by Hybrid Neuro Fuzzy Approach, Int. J. of Electrical Power and Energy Systems Engineering, vol. 2, no. 1, 2009, pp. 13-18.
- [4] S. Ramesh, and A. Krishnan, Modified Genetic Algorithm Based Load Frequency Controller for Interconnected Power System, Int. J. of Electrical and Power Engineering, vol. 3, no. 1, 2009, pp. 26-30.
- [5] P. Aravindan and M.Y.Sanavullah , Fuzzy Logic Based Automatic Frequency Control of Two Area Power System with GRC, Int. J. of Computational Intelligence Research, vol. 5, no. 1, 2009, pp. 37-44.
- [6] G. Ziegler and N.B. Nichols, 1942, Optimum settings for automatic controllers, Trans. ASME, 64,759-768.
- [7] D.B. Fogel, Evolutionary Computation toward a New Philosophy of Machine Intelligence, New York, IEEE, 1995.
- [8] S.R. Karnik, A.B. Raju and M.S. Raviprakash, Genetic Algorithm based Robust Power System Stabilizer Design using Taguchi Principle, First International Conference on Emerging Trends in Engineering and Technology, Nagpur, Maharashtra, 2008, pp. 887-892.
- [9] O.I. Elgard, Electric Energy Systems Theory”, Mc Graw-Hill, New York, pp. 299-362, 1982.
- [10] E. Swidenbank., M.D. Brown and D. Flynn, “Self-Tuning Turbine Generator Control for Power Plant, Mechatronics, Vol. 9, 1999, pp. 513-537.
- [11] Z.L. Gaing, A Particle Swarm Optimization Approach for Optimum Design of PID Controller in AVR System, IEEE Transactions on Energy Conversion, Vol. 19, No. 2, pp. 348-391, 2004.
- [12] O.I. Elgerd, Electrical energy system theory – An introduction, Mc Graw – Hill, New Delhi, 1983.
- [13] M.E. Tacer. Enerji Sistemlerinde Kararlılık, ITU Kutuphanesi, Sayı:1407, 1990.
- [14] I.H. Atlas, Güç Uyarım Sistemlerinin Denetiminde Bulanık Mantık, Otomasyon Dergisi, Bilesim Yayıncılık A.S., Sayı: 9, Sy: 123–128, İstanbul, 2000.
- [15] B.T. Yuan, D.Z. Xia, Y.X. Ni, Eigen Analysis Method for Stability Evaluation of Linear Constant- Coefficient RDDE and its Application to Power System, In Proc. Of IEEE Region 10 Conf. On Comp. Comm., Cont. and Power Eng. Beijing, China,1993, pp:153-156, 19-21.
- [16] H. Wu, H. Ni, G.T. Heydt, The Impact of Time Delay on Robust Control Design in Power Systems, in Proc. IEEE PES Winter Meeting, Vol. 2, 2002, pp:27–31.
- [17] H. Yoshida, K. Kawata and Y. Fukuyama, A particle swarm optimization for reactive power and voltage control considering voltage security assessment, IEEE Trans. Power Syst., vol. 15, 2000, pp. 1232–1239.
- [18] E. Yalcin , E. Cam, T. Vardar and M. Luy, PID Kontrolör ile iki Bolgeli Güç Sistemlerinde Yuk Frekans Kontrolünün incelenmesi, Int. J. Eng. Research & Development, 2 (1), 2010,167-71.
- [19] D.E. Goldberg, Genetic Algorithms in Search Optimization and Machine Learning, Addison, MA:Wesley Longman, 1989.
- [20] B. Schutz, Gravity from the Ground Up, Cambridge University Press, 2003.
- [21] D. Holliday, R. Resnick and J. Walker, 1993, Fundamentals of physics, John Wiley and Sons, 4th edition 1993, 196-197.
- [22] R. Mansouri, F. Nasserı and M. Khorrami, 1999, Effective time variation of G in a model universe with variable space dimension, Physics Letters 259 194–200.
- [23] E. Rashedi, 2007 Gravitational Search Algorithm, M.Sc. Thesis, Shahid Bahonar University of Kerman, Kerman, Iran, (2007 in Farsi).
- [24] E. Rashedi, H. Nezamabadi-Pour and S. Saryazd, 2009, GSA: A Gravitational Search Algorithm, Information Sciences 179, 2232–2248.