

Fractional Order Two-Port Network Oscillators Based on Single Non-Zero Transmission Matrix Element

Lobna A. Said¹, Ahmed G. Radwan^{2,3}, Ahmed H. Madian^{3,4}, Ahmed M. Soliman⁵

¹Faculty of IET, German University in Cairo (GUC), Egypt.

²Dept. of Engineering Mathematics and Physics, Cairo University, Egypt.

³NISC Research Center, Nile University, Cairo, Egypt

⁴Radiation Engineering Dept., NCRRT, Egyptian Atomic Energy, Authority.

⁵Electronics and comm. Eng. Dept., Cairo University, Egypt.

Abstract

A study of two port network fractional order oscillator is presented in this paper. The presented oscillator consists of a general two port network and three impedances. The oscillator design depends on the numbers of elements in the two port network transmission matrix. Networks with only single element in its transmission matrix is discussed which gives four possible networks. The impedances associated with the studied networks are series or parallel connection of resistors in addition to fractional order capacitors. The characteristic equation, oscillation frequency and condition for each combination are introduced. Numerical discussions of the presented oscillators with Spice simulations are presented.

1. Introduction

A two-port network is an electrical network with two ports for input and output. The port is characterized by the voltages and currents at its input and output terminals. The terms relate these voltages and currents are called parameters which completely describe the network behavior [1]. The transmission matrix is one of the famous ways to characterize the network which is suitable for cascaded connection. It relates the input port with the output port as follows:

$$\begin{bmatrix} V_1 \\ I_1 \end{bmatrix} = \begin{bmatrix} a_{11} & a_{12} \\ a_{21} & a_{22} \end{bmatrix} \begin{bmatrix} V_2 \\ -I_2 \end{bmatrix} \quad (1)$$

Enormous amount of literature employ the two port network in many applications in the field of electrical engineering [2-4], control engineering [5] and mechanical engineering [6]. Novel non-balanced non-matched cross-coupled oscillators was demonstrated in [2] with the use of the two-port network transmission parameters. All possible canonical second-order single transistor oscillators derived from the general class-A or class-B two-port network topologies was presented in [3]. A linear transformation based on the two port network concept used in building LC ladder filters was presented in [4].

The fractional calculus is the branch of mathematics generalizes the integer order differentiation and integration. It was known since the integer calculus, yet its breakthrough in the field of science and engineering started in the early sixty [7-15].

It has lots of contributions in biomedical engineering [7], control engineering [8-9], signal processing [10], and electrical engineering [11-15]. One of the famous definitions of the fractional order derivatives is the Riemann-Liouville definition described by:

$$D_{t_0}^{\alpha} f(t) = \frac{1}{\Gamma(m-\alpha)} \frac{d^m}{dt^m} \int_{t_0}^t f(u) (t-u)^{m-\alpha-1} du \quad (2)$$

where m is an integer such that $(m-1) < \alpha < m$. The fractional calculus adds extra degree of freedom which is the fractional order parameter. This advantage increases the design flexibility and controllability.

The idea is to employ a two port network with only one element in its transmission matrix. Various impedances combination are employed to obtain a valid oscillation parameters for each network. The impedances discussed throughout the paper are combinations of series or parallel connection of fractional order capacitors with resistors.

This paper is organized as follows; section 2 presents the configuration of the two-port network oscillator. Section 3 discusses the design of oscillator based on a network with one element in its transmission matrix with numerical discussions. Section 4 presents Spice simulations for some cases, finally section 5 concludes the work.

2. Oscillator Structure

The suggested oscillator is depicted in Fig.1 consists of a general two port network with input impedance Z_1 , output impedance Z_2 and a feedback impedance Z_3 . From Fig.1, $I_2 = I_{Z_3} - I_{Z_2}$, so I_2 can be written as:

$$I_2 = \frac{V_1}{Z_3} - V_2 \left(\frac{1}{Z_3} + \frac{1}{Z_2} \right) \quad (3)$$

With the transmission matrix in (1) and the above equation:

$$\frac{V_1}{V_2} = \frac{a_{11} + a_{12} \left(\frac{1}{Z_3} + \frac{1}{Z_2} \right)}{1 + a_{12}/Z_3} \quad (4)$$

Also, $I_1 + I_{Z_1} + I_{Z_3} = 0$, so I_1 can be written as:

$$I_1 = \frac{V_2}{Z_3} - V_1 \left(\frac{1}{Z_3} + \frac{1}{Z_1} \right) \quad (5)$$

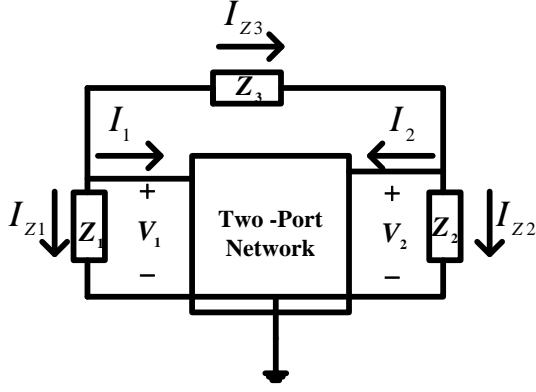

Fig. 1. Oscillator structure.

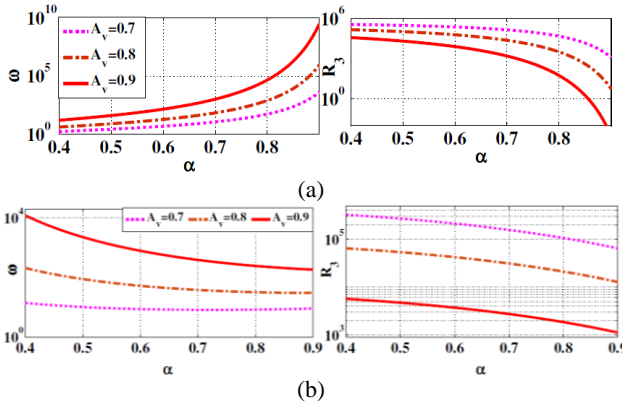

Fig. 2. Oscillator parameters for VCVS versus α with (a) $\beta = 1$, and (b) $\beta = 1.5\alpha$

Table 1. Single element networks

Network	Transmission matrix	Characteristic equation
VCVS	$\begin{bmatrix} A_v & 0 \\ 0 & 0 \end{bmatrix}$	$A_v Z_2 Z_3 + (A_v - 1) Z_1 Z_2 = 0$
VCCS	$\begin{bmatrix} 0 & R_m \\ 0 & 0 \end{bmatrix}$	$-Z_1 Z_2 + R_m (Z_1 + Z_2 + Z_3) = 0$
CCVS	$\begin{bmatrix} 0 & 0 \\ G_m & 0 \end{bmatrix}$	$G_m Z_1 Z_2 Z_3 - Z_1 Z_2 = 0$
CCCS	$\begin{bmatrix} 0 & 0 \\ 0 & A_i \end{bmatrix}$	$A_i Z_1 Z_3 + (A_i - 1) Z_1 Z_2 = 0$

With the transmission matrix in (1) and the above equation; another relation between (V_1/V_2) can be written as follows:

$$\frac{V_1}{V_2} = \frac{a_{12}/Z_3 + |A|}{a_{12} \left(\frac{1}{Z_3} + \frac{1}{Z_1} \right) + a_{22}} \quad (6)$$

By eliminating (V_1/V_2) , the characteristic equation of this oscillator is obtained in terms on the transmission matrix elements and the three impedances.

$$a_{21} Z_1 Z_2 Z_3 + a_{11} Z_2 Z_3 + a_{22} Z_1 Z_3 + (a_{11} + a_{22} - 1 - |A|) Z_1 Z_2 + a_{12} (Z_1 + Z_2 + Z_3) = 0 \quad (7)$$

3. Single element network

There is lots of linear controlled networks can be arranged in a matrix form such as the voltage- controlled voltage source (VCVS), the voltage-controlled current source (VCCS), the current-controlled voltage source (CCVS) and the current controlled current source (CCCS). The transmission matrix of all these networks contains only one element as illustrated in Table 1. It also shows the oscillator's characteristic equation when each network is used where it is independent of some impedances which will be considered as open circuit (O C) as follows:

- For the VCVS, the output impedance Z_2 .
- For the CCCS, the input impedance Z_1 .
- For the CCVS, both input and output impedances Z_1 & Z_2 .

Obviously from Table 1, The characteristic equation of The CCCS is similar to the VCVS replacing Z_1 by Z_2 with $A_i = A_v$. The choice of impedances depends on the characteristic equation of each network to obtain valid oscillations.

The theory of fractional order oscillator was presented in [11] and it is applied throughout this paper. Table 2 summarizes the possible impedance combinations, characteristic equation, oscillation frequency and condition for each network.

For the VCVS (or CCCS), only the parallel combination achieves oscillations. The oscillation frequency is completely controlled by the fractional order parameters β & α and the voltage gain A_v which must be less than one. The oscillation frequency is independent of the resistors R_1 & R_3 which control the oscillation condition. The cases where $\beta = \alpha$ are not a working oscillator which include the integer case. Figure 2 shows the oscillation parameters versus α for different β and with R_1 open circuit where it is clear that increasing A_v leads to increase in the obtained frequency range. There exists inverse relation between the frequency of oscillation and R_3 . When mixing integer order capacitors $\beta = 1$ with different fractional order ones, higher frequency range is obtained as deduced from Fig.2.

For the VCCS, the three impedances exist which allow six possible combinations to achieve oscillations. Without any loss of generality, interchanging Z_1 & Z_2 would lead to identical response so only four combinations are studied in Table 2. The cases where $\beta = \alpha$ are not valid oscillators including the integer case for the four combinations. For combination 1, if $g_3 = g_2 = 0$ (OC) and for combination 2 if $R_3 = R_2 = 0$ (short circuit (SC)), the two cases will be equivalent. Figure 3 shows the surfaces of oscillation frequency and condition for these cases versus $\alpha - \beta$ plane where the oscillation frequency range reaches tens K rad/sec. Figure 4 illustrates the effect of the added resistance for combinations 1 & 2 on the oscillation parameters versus α at $\beta = 1$. For combination 1, increasing the parallel resistance, increases the frequency range. However, for combination 2, decreasing the series resistance increases the obtained frequency range.

From Table 2, if pure fractional capacitors were used for combinations 3 & 4, there exist a condition on the fractional order parameters to have a working condition of oscillation or a negative resistance is needed to obtain oscillations. The condition is $\alpha + \beta > 2$ which contradict with the oscillation frequency equation. This can be overcome through the negative implementation of VCCS. Figure 5 shows the oscillation parameters surfaces versus $\alpha - \beta$ plane where a very large

resistance is needed to achieve small values of frequency reaches hundreds rad/sec.

Table 2. Impedance combinations, characteristic equation and oscillation parameters for single element network

	#	Impedances			Characteristic equation	ω	Condition
		Z_1	Z_2	Z_3			
VCCS	1		O C		$\frac{s^\alpha}{kC_3} + \frac{s^\beta}{C_1} + \frac{g_1+kg_3}{kC_1C_3} = 0$ $, k = \frac{(A_v-1)}{A_v}$	$\omega^{\beta-\alpha} = \frac{-C_1 \sin(\frac{\alpha\pi}{2})}{kC_3 \sin(\frac{\beta\pi}{2})}$	$g_3 = \frac{\cos(\frac{\alpha\pi}{2}) C_1 \omega^\alpha + kC_3 \cos(\frac{\beta\pi}{2}) \omega^\beta + g_1}{-k}$
	1	R			$s^{\alpha+\beta} + \left(\frac{g_3}{C_3} + \frac{1}{C_3 R}\right) s^\alpha + \left(\frac{g_2}{C_2} + \frac{1}{C_2 R}\right) s^\beta + \frac{g_2 g_3}{C_2 R m} - \frac{1}{C_2 C_3} = 0$	$\frac{\omega^{2\alpha+\beta} \sin(\frac{\beta\pi}{2})}{C_3} + \frac{\omega^{\alpha+2\beta} \sin(\frac{\alpha\pi}{2})}{C_2} + \frac{\omega^{\alpha+\beta}}{C_2 C_3} \left((g_2 + g_3) \sin\left(\frac{(\beta+\alpha)\pi}{2}\right) + (g_2 - g_3 - \frac{1}{R_m}) \sin\left(\frac{(\beta-\alpha)\pi}{2}\right) \right) + \frac{g_3 (g_3 + \frac{1}{R_m}) \omega^\alpha \sin(\frac{\alpha\pi}{2})}{C_2 C_3^2} + \frac{g_2 (g_2 - \frac{1}{R_m}) \omega^\beta \sin(\frac{\beta\pi}{2})}{C_3 C_2^2} = 0$	$R = \frac{-\frac{\omega^\alpha \sin(\frac{\alpha\pi}{2})}{C_3} - \frac{\omega^\beta \sin(\frac{\beta\pi}{2})}{C_2}}{\omega^{\alpha+\beta} \sin(\frac{(\beta+\alpha)\pi}{2}) + \frac{g_3 \omega^\alpha \sin(\frac{\alpha\pi}{2})}{C_3} + \frac{(R_m g_2 - 1) \omega^\beta \sin(\frac{\beta\pi}{2})}{C_2 R_m}}$
	2	R			$\left(\frac{R + R_2 + R_3 - \frac{R_2 R}{R_m}}{R_m}\right) s^{\alpha+\beta} + \frac{1}{C_3} s^\alpha + \frac{(R_m - R)}{C_2 R_m} s^\beta = 0$	$\omega^\alpha C_2 (R_m - R_2) \sin\left(\frac{\beta\pi}{2}\right) + C_3 (R_m + R_3) \omega^\beta \sin\left(\frac{\alpha\pi}{2}\right) = \sin\left(\frac{(\beta-\alpha)\pi}{2}\right)$	$R = \frac{-\omega^{\alpha+\beta} (R_2 + R_3) \sin\left(\frac{(\beta+\alpha)\pi}{2}\right) - \frac{\omega^\beta \sin(\frac{\beta\pi}{2})}{C_2} - \frac{\omega^\alpha \sin(\frac{\alpha\pi}{2})}{C_3}}{\frac{\omega^{\alpha+\beta} (R_m - R_2) \sin\left(\frac{(\beta+\alpha)\pi}{2}\right)}{R_m} + \frac{\omega^\beta \sin(\frac{\beta\pi}{2})}{C_2 R_m}}$
	3			R	$s^{\alpha+\beta} + \left(\frac{g_2}{C_2} + \frac{1}{C_2 R}\right) s^\alpha + \left(\frac{g_1}{C_1} + \frac{1}{C_1 R}\right) s^\beta + \frac{g_2 + g_1 + R g_2 g_1}{C_1 C_2 R} - \frac{1}{C_1 C_2 R R_m} = 0$	$\frac{\omega^{2\alpha+\beta} \sin(\frac{\beta\pi}{2})}{C_2} + \frac{\omega^{\alpha+2\beta} \sin(\frac{\alpha\pi}{2})}{C_1} + \frac{\omega^{\alpha+\beta}}{C_1 C_2} \left((g_2 + g_1 - \frac{1}{R_m}) \sin\left(\frac{(\beta+\alpha)\pi}{2}\right) - (g_2 - g_1) \sin\left(\frac{(\beta-\alpha)\pi}{2}\right) \right) + \frac{g_2 (g_2 - \frac{1}{R_m}) \omega^\alpha \sin(\frac{\alpha\pi}{2})}{C_1 C_2^2} + \frac{g_1 (g_1 - \frac{1}{R_m}) \omega^\beta \sin(\frac{\beta\pi}{2})}{C_2 C_1^2} = 0$	$R = \frac{-\frac{\omega^\alpha \sin(\frac{\alpha\pi}{2})}{C_2} - \frac{\omega^\beta \sin(\frac{\beta\pi}{2})}{C_1}}{\omega^{\alpha+\beta} \sin\left(\frac{(\beta+\alpha)\pi}{2}\right) + \frac{g_2 \omega^\alpha \sin(\frac{\alpha\pi}{2})}{C_2} + \frac{g_1 \omega^\beta \sin(\frac{\beta\pi}{2})}{C_1}}$
4			R	$\left(\frac{R + R_2 + R_1 - (R_2 R_1 / R_m)}{R_m}\right) s^{\alpha+\beta} + \frac{(R_m - R_1)}{C_2 R_m} s^\alpha + \frac{(R_m - R_2)}{C_1 R_m} s^\beta - \frac{1}{C_1 C_2 R_m} = 0$	$\omega^\alpha C_1 (R_m - R_1) \sin\left(\frac{\beta\pi}{2}\right) + C_2 (R_m - R_2) \omega^\beta \sin\left(\frac{\alpha\pi}{2}\right) = \sin\left(\frac{(\beta+\alpha)\pi}{2}\right)$	$R = \frac{(R_2 + R_1 - \frac{R_2 R_1}{R_m}) \sin\left(\frac{(\beta+\alpha)\pi}{2}\right) + \frac{\omega^{-\alpha} (R_m - R_2) \sin(\frac{\beta\pi}{2})}{C_1} + \frac{(R_m - R_1) \omega^{-\beta} \sin(\frac{\alpha\pi}{2})}{C_2}}{-\sin\left(\frac{(\beta+\alpha)\pi}{2}\right)}$	
CCCS	1	O C			$\frac{s^\alpha}{kC_3} + \frac{s^\beta}{C_2} + \frac{g_2+kg_3}{kC_2C_3} = 0$ $, k = \frac{(A_i-1)}{A_i}$	$\omega^{\beta-\alpha} = \frac{-C_2 \sin(\frac{\alpha\pi}{2})}{kC_3 \sin(\frac{\beta\pi}{2})}$	$g_3 = \frac{\cos(\frac{\alpha\pi}{2}) C_2 \omega^\alpha + kC_3 \cos(\frac{\beta\pi}{2}) \omega^\beta + g_2}{-k}$

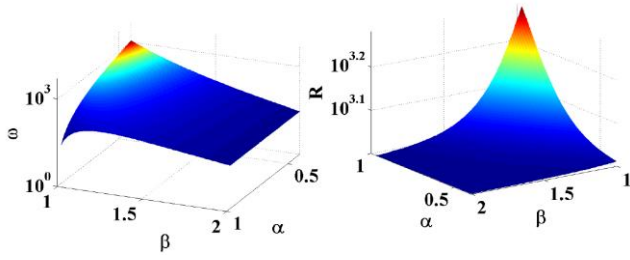
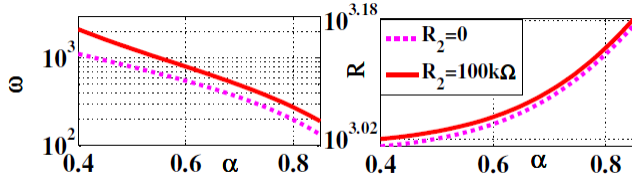
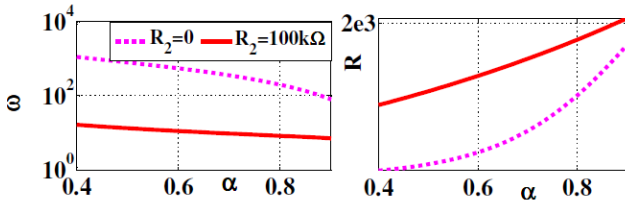

Fig. 3. Oscillator parameters surfaces for VCCS combination 1 & 2 with no resistances versus $\alpha - \beta$ plane.



(a)



(b)

Fig. 4. Oscillation parameters for VCCS versus α for $R_3 = R_2$, $\beta = 1$ (a) Combination 1, and (b) Combination 2.

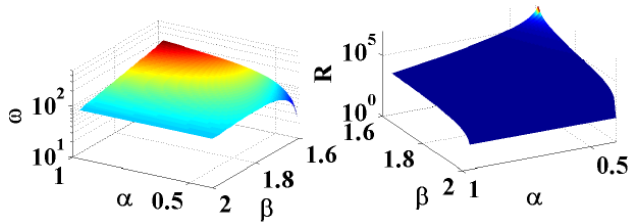
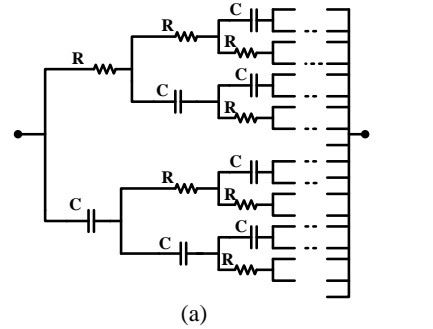

Fig. 5. Oscillator parameters surfaces for VCCS combination 3 & 4 with no resistances versus $\alpha - \beta$ plane.

4. Simulation results

In this section, Simulation of some cases are presented to verify the reliability of the proposed oscillators. Equal C design is chosen to be simulated over all cases with $C_1 = C_2 = 1.2 \times 10^{-6}$. The fractional order capacitor is simulated as shown in Fig. 6. It shows the approximation of fractional order capacitor with order 0.5 [14] and with any other order [15]. The number of branches depends on the order of the capacitor [15]. For the VCCS, combination 1 & 2 with $R_3 = R_2 = 0$ and $g_3 = g_2 = 0$, when $\alpha = 0.8, \beta = 1$ the frequency of oscillation is calculated to be 32Hz and $R = 1.4k\Omega$. The output waveforms for this oscillator are shown in Fig. 7(a). When $\alpha = 0.6, \beta = 1$ the frequency of oscillation is calculated to be 88Hz and $R = 1k\Omega$. The output waveforms for this oscillator are shown in Fig. 7(b).



(a)

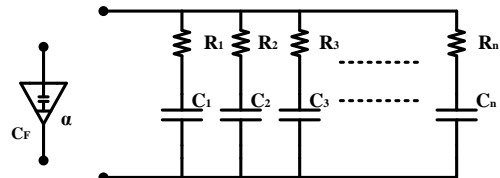

(b)

Fig. 6. Approximation the capacitor with (a) order 0.5, and (b) general order

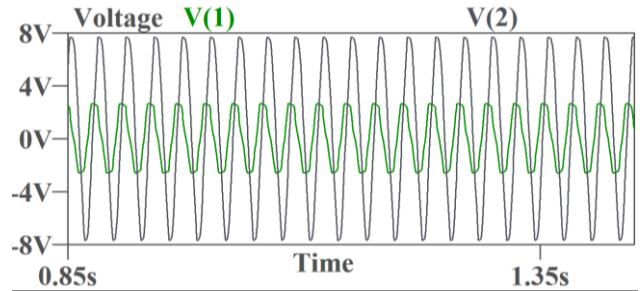

(a)

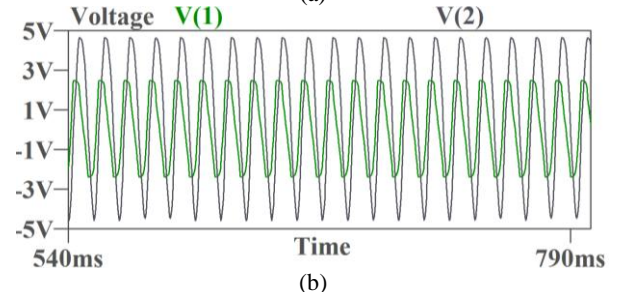

(b)

Fig. 7. Spice simulations with VCCS for $\beta = 1$ (a) $\alpha = 0.8$, and (b) $\alpha = 0.6$

5. Conclusions

In this paper, a study of fractional order oscillator based on two port network with a single element in its transmission matrix was presented. Four devices were studied as a two port network. Different impedance combinations were investigated to achieve oscillations. The oscillation frequency and condition were investigated for each combination. The fractional order parameter adds extra degree of freedom in the design which increases the design flexibility. Numerical and circuit simulation results for some cases were illustrated.

6. References

- [1] C. Alexander, and M. Sadiku, "Fundamentals of electric circuits", McGraw-Hill, Singapore, 2007.
- [2] A. S. Elwakil, "Design of non-balanced cross-coupled oscillators with no matching requirements", *IET Circ. Dev. Syst.*, vol. 4, no.5, pp.365–373, 2010.
- [3] A. S. Elwakil, "All possible canonical second-order three-impedance class-A and class-B oscillators," *Electron. Letter.*, vol. 46,no. 11,2010.
- [4] L. A. Said, A. H. Madian, M. H. Ismail, and A. M. Soliman, "Active realization of doubly terminated LC ladder filters using current feedback operational amplifier (CFOA) via linear transformation", *Int. J. Electron. Comm.* vol. 65, pp. 753–762, 2011.
- [5] M. C. Tsai, and D. W. Gu, "Robust and optimal control:A two-port framework approach,advances in industrial control", Springer-Verlag London, 2014.
- [6] J. Kim, W.-S. Ohm,and N.-C. Park, "Two-Port Network Model of Fluid-Loaded SAW Delay-Line Sensors", *ASME Int. Mech. Eng. Congress Exposition*, 2011.
- [7] R. L. Magin, "Fractional Calculus in Bioengineering", Begell House Publishers, 2006.
- [8] M. Axtell, and E. M. Bise, "Fractional calculus applications in control systems", *Proc. of the IEEE Nat. Aerospace and Electronics Conf.*, pp. 563–566, 1990.
- [9] B.M. Vinagre, I. Podlubny, A. Hernandez, and V. Feliu, "approximations of fractional order operators used in control theory and applications", *Fractional Calculus Appl. Anal.*, vol. 3, pp. 231–248, 2000.
- [10] C. C. Tseng, "Design of FIR and IIR fractional order Simpson digital integrators", *Signal Process.* vol. 87, pp. 1045–1057, 2007.
- [11] A. G. Radwan, A. M. Soliman, A.S. Elwakil, "Design equations for fractional-order sinusoidal oscillators: four practical circuits examples", *Int. J. Circ. Theor. Appl.*, 36, 473-492, 2008.
- [12] A. G. Radwan and K.N. Salama, "Passive and Active Elements Using Fractional $L_\beta C_\alpha$ Circuit", *IEEE Trans. Circ. Syst.*, vol. 58, pp 2388-2397, 2011.
- [13] G. E. Carlson and C. A. Halijak, "Approximation of fractional capacitors $(1/s)^{1/n}$ by a regular Newton process", *IEEE Trans. Circ. Theor.*, vol. 11, pp. 210-213, 1964.
- [14] M. Nakagava, and K. Sorimachi, "Basic characteristics of a fractance device", *IEICE Trans. fundamentals*, pp. 1814–1818, 1992.
- [15] M. Sugi, Y. Hirano, Y. F. Miura and K. Saito, "Simulation of fractal immittance by analog circuits: An approach to the optimized circuits", *IEICE Trans. fundamentals*, Vol .E82, no.8, pp.205-209, 1999.