

Electronic Differential System for an Electric Vehicle with In-Wheel Motor

Merve Yıldırım¹, Eyyüp Öksüztepe², Burak Tanyeri³, and Hasan Kürüm⁴

^{1,4}Dept. of Electrical and Electronics Eng., Firat University, Turkey
merveyildirim@firat.edu.tr, hkurum@firat.edu.tr

²School of Avionics, Firat University, Turkey
eoksuztepe@firat.edu.tr

³Dept. of Automotive Engineering, Firat University, Turkey
btanyeri@firat.edu.tr

Abstract

This paper presents modeling and simulation of Electronic Differential System (EDS) for the dual-front-wheel independently driven Electric Vehicle (EV). Electronic differential is utilized in EVs due to some drawbacks of traditional mechanical differential such as being heavy and bulky systems which are not convenient for EV, and mechanical losses caused by the powertrains. In this study, an EDS for front wheels of an EV with in-wheel motor is modelled instead of rare wheels which has commonly been studied in the literature. The front wheel speeds are estimated by equations derived from Ackermann-Jeantand model using Codesys Software Package. Then, the simulation of EDS is also realized by Matlab/Simulink. According to the change of the vehicle speed and steering angle of EV, front wheel speeds estimated by Codesys are verified by Simulink results. It is observed that the modelled EDS is appropriate for EVs with in-wheel motors.

Keywords: Electric Vehicle, In-wheel Motor, Electronic Differential System

1. Introduction

Expansion of transportation sector causes some issues which are increasing of environment pollution and depletion of fossil fuels. Therefore, EVs are used for eliminating the emission of the harmful gases, reducing dependence on the countries imported oil by providing fuel-saving, and prevention of air pollution. In recent years, using of EVs has increased due to developments in driver and battery technology, using of efficient electric motors, and safe driving [1, 2].

The mass of an EV which has one traction-motor driving two wheels using a differential gear increases due to the batteries. To reduce the mass of the EV and using of the drive-trains, get fast response from the motors, and provide independent torque control of each wheel, the motors are fitted into the wheels [3, 4].

Differential systems for the vehicles are used in slippery and sloping roads to distribute power and torque equally to the traction wheels. Internal combustion engine vehicles have a mechanical differential using a differential gear. Once a wheel accelerates in case of not using the differential gears, the wheels slip due to braking to decelerate the other one. This also causes unsafe driving, increasing of fuel consumption and tyre wear. Therefore, the speed of the inner wheel has to be different from the speed of the outer wheel for a vehicle driving on a curved

road [5]. On the other hand for EVs, an EDS is utilized due to having independent directly driven wheels instead of a traditional differential gear. Hence, some drawbacks such as mechanical losses, maintenance, and repair costs of gears caused by the powertrains are also eliminated.

As examined the studies on EDS in the literature, modeling and simulation of EDS for an EV with two-motor-wheel drive are realized by the fuzzy logic control method used to estimate the slip rate of each wheel in [3]. Designed EDS is verified by Matlab/Simulink results. Azeddine Draou carries out electronic differential speed control for two in-wheel motors drive vehicle in [6]. The method includes the direct torque control for each in-wheel motor which is Permanent Magnet Synchronous Motor (PMSM). The designed system is simulated for different road scenarios which are straight and curved roads. It is observed that stability of the vehicle is provided well in the curved road. In [7], an electric differential system for two independent rear wheels of EV is presented and analysis of a speed and torque observer for DC motor is carried out. Rear wheel torque vectoring algorithm based on Ackermann Jeantand model is designed for dual motor electric drive system in [8]. The simulation of the system is realized in Excel to show different cornering cases. Authors in [9] propose a speed control method for differential steering of four wheel independent driving EV. The equations are given by Ackermann Jeantand model based on the vehicle speed. The accuracy of designed system is proved by both simulation and experimental results. [5] includes a neural network model which is used for an analysis based on the vehicle speed and steering angle of an EDS for EV. It is seen that designed EDS is useful for EV. In another paper [10], an EDS for EV with two independent rear wheel drives is designed by neural network control used for estimating the vehicle speed. According to the change of the vehicle speed, the speeds of the rear wheel drives are obtained by this method. The simulation results are verified by testing two 37-kW induction motors. Electronic differential speed steering control for four in-wheel motor independent drives of EV is handled by Neural Networks PID electronic differential in [11]. It is seen that the simulation results based on the vehicle speed and steering angle are satisfactory. [12] presents a new EDS control architecture for the traction system in rear electric traction passenger hybrid electric vehicles (HEVs). Kinematic and dynamic models of the vehicle are given in this study. The simulation results are tested successfully taking experimental results by a HEV in Low Scale (HELVIS)-Sim simulation. As a result, it is observed that the studies on the EDS for rare in-wheel motors of EV have been generally realized in the literature. On the contrary in this paper, an EDS for front in-wheel motors of EV has been modelled.

According to the change of the steering angle and speed of EV, the speeds of the front in-wheel motors have been estimated by Codesys Software Package using mathematical equations obtained from Ackermann-Jeantand model. The steering angle information has been received by a position encoder via Controller Area Network-Bus (CAN-Bus) protocol. CAN-Bus protocol are commonly used in EVs due to having significant advantages for EV such as being fast, flexible, and reliable, equal message access, using fewer cables thus, low cost and vehicle weight. Then, Matlab/Simulink modelling has been realized by using the equations. According to the change of the steering angle, the speeds of front in-wheel motors for EV have been obtained by both Codesys Software Package and Matlab/Simulink. Codesys results have been verified by comparing with Simulink results.

This paper is organized that Section II describes EDS for EV. Besides, Ackermann-Jeantand model of driving trajectory at low speeds is comprehensively explained in this section. In Section III, Matlab/Simulink modelling of EDS is carried out. Codesys results are compared with Simulink results. Conclusions are given at the end.

2. Electronic Differential System for EV

EDS plays a significant role for EVs. According to the road curve, the speed of the inner wheel must be less than the speed of the outer wheel. In this study, Ackermann-Jeantand model is preferred in the EDS design. This model was discovered by Rudolf Ackermann in the 19th century and it gives the relationship between the inner and outer wheels on a curved road [13]. It is commonly used at low speeds due to the effect of centrifugal force and centripetal forces when driving on a curved road [14]. The tires are not considered in this model. Some parameters such as the road curvature radius, speed of the vehicle, distance between the front and rear wheel, steering angle, distance between rear wheels are included in the model. Ackermann-Jeantand model of EDS for the dual-front-wheel independently driven electric vehicle (EV) is shown in Fig. 1.

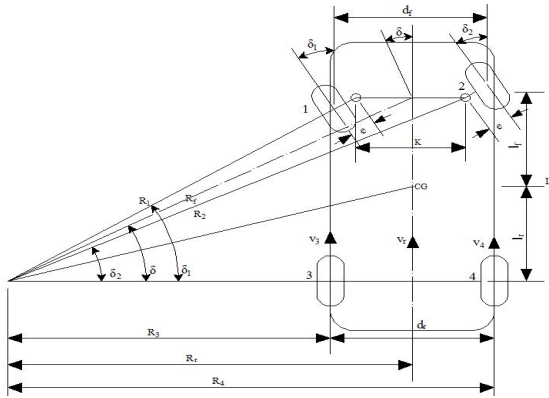

Fig. 1. Ackermann-Jeantand model of driving trajectory at low speeds [3].

A position encoder is used for the steering angle. When the steering angle is zero, it means that EV drives on a straight road. Once the steering angle is different from zero, it means that the wheels of EV turn left or right and the speed of the inner wheel has to be less than the speed of the outer wheel according to the turning direction [15]. In this situation, the EDS is activated. If the steering angle (δ) > 0 is, the EV drives left and if δ < 0 is, the

EV drives right. If $\delta=0$ is, the EV drives straight ahead [14, 3].

The equations derived from this model are as follow

The inner steering angle of the front wheel is given by

$$\delta_1 = \arctan \left[\frac{L \cdot \tan(\delta)}{L - ((K/2) \cdot \tan(\delta))} \right] \quad (1)$$

The outer steering angle of the front wheel is given by

$$\delta_2 = \arctan \left[\frac{L \cdot \tan(\delta)}{L + ((K/2) \cdot \tan(\delta))} \right] \quad (2)$$

where K is the distance between the left and right kingpin, L is the distance between the front and rear wheel, δ is the steering angle.

To estimate the speeds, the turning radii of the front inner and outer wheels, rear inner and outer wheels can be respectively expressed by

$$R_1 = \frac{L}{\sin(\delta)} \quad (3)$$

$$R_2 = \frac{L}{\sin(\delta)} \quad (4)$$

$$R_3 = \frac{L}{\tan(\delta)} - \frac{d_r}{2} \quad (5)$$

$$R_4 = \frac{L}{\tan(\delta)} + \frac{d_r}{2} \quad (6)$$

where d_r is the distance between rear wheels.

The radius of the gravity centre of EV is

$$R_{cg} = \sqrt{(R_3 + (d_r/2))^2 + (l_r)^2} \quad (7)$$

where l_r is the distance between the rear wheel and gravity centre.

The angular speeds of the front inner and outer wheels, and rear inner and outer wheels can be respectively expressed by

$$w_1 = \frac{V \cdot R_1}{(R_{cg}) \cdot r} \quad (8)$$

$$w_2 = \frac{V \cdot R_2}{(R_{cg}) \cdot r} \quad (9)$$

$$w_3 = \frac{V \cdot R_3}{(R_{cg}) \cdot r} \quad (10)$$

$$w_4 = \frac{V \cdot R_4}{(R_{cg}) \cdot r} \quad (11)$$

where r is the radius of the wheel and V is the speed of EV.

The equations which are derived from Ackermann-Jeantand geometry are given into the Codesys Software Package. L , l_r , d_r , r , and K parameters whose values are taken from a vehicle are used as the constant values in the programme. These parameter values are shown in Table 1. The steering wheel position is taken by using an encoder over CAN-Bus. This position value is converted to the angle in Codesys Software. While the speed of an EV having 21-inch wheel size is 50 km/h, the vehicle speed corresponding this value is 505.538 rpm. Therefore, this speed value is used in the software. According to the different steering angles and speed of the EV, the speeds of the front wheels are estimated by Codesys Software. The simulation of EDS realized by Codesys is illustrated in Fig. 2.

Table 1. EDS model parameters

| Parameters | Values (mm) |
|------------|-------------|
| L | 2.285 |
| l_r | 0.835 |
| d_r | 1.35 |
| r | 0.395 |
| K | 1.219 |

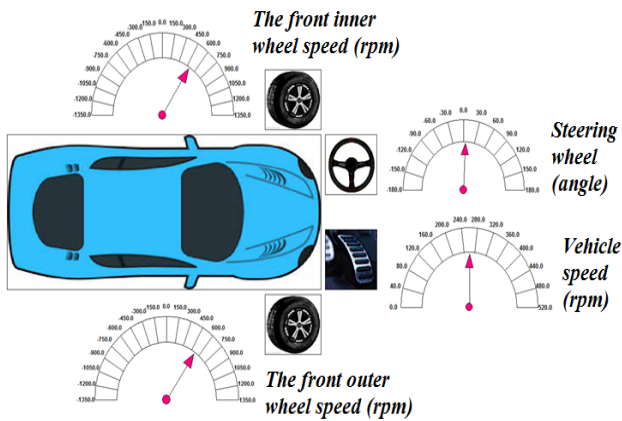

Fig. 2. Codesys simulation of EDS

3. Matlab/Simulink Simulation Model and Results

The simulation of EDS is also realized by Matlab/Simulink to validate the front wheel speeds of EV estimated by Codesys. The simulation model is shown in Fig. 3. Once the steering angle and the speed of the EV are respectively taken as 1° and 505.538 rpm that is the speed corresponding 50 km/h, the wheel speeds estimated by Simulink are shown in Fig. 4. In case of changing the steering angle from 1° to 15° with a degree range, Codesys results of front wheel speeds (n_1 , n_2) are compared with Simulink results in Table 2 and Table 3 based on the direction of the steering wheel.

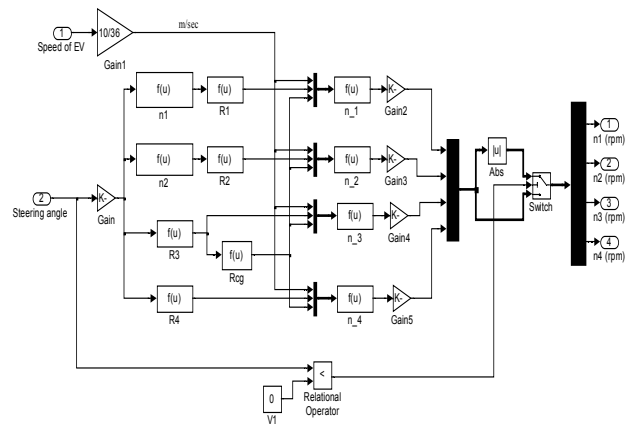

Fig. 3. Matlab/Simulink model of EDS

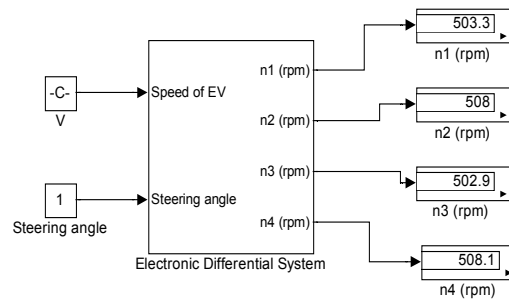

Fig. 4. Matlab/Simulink results of EDS

Table 2. Comparison of Simulink and Codesys results

| Steering Angle (Degree) | Codesys Results (rpm) | | Simulink Results (rpm) | | Error (%) | |
|-------------------------|-----------------------|---------|------------------------|-------|-----------|-------|
| | n_1 | n_2 | n_1 | n_2 | n_1 | n_2 |
| 0 | 505.538 | 505.538 | 505.5 | 505.5 | 0.007 | 0.008 |
| 1 | 503.251 | 507.958 | 503.3 | 508 | 0.009 | 0.008 |
| 2 | 501.099 | 510.510 | 501.1 | 510.5 | 0.0002 | 0.002 |
| 3 | 499.083 | 513.195 | 499.1 | 513.2 | 0.0034 | 0.001 |
| 4 | 497.204 | 516.01 | 497.2 | 516 | 0.0008 | 0.002 |
| 5 | 495.464 | 518.957 | 495.5 | 519 | 0.0073 | 0.008 |
| 6 | 493.865 | 522.035 | 493.9 | 522 | 0.0071 | 0.007 |
| 7 | 492.409 | 525.243 | 492.4 | 525.2 | 0.0018 | 0.008 |
| 8 | 491.098 | 528.583 | 491.1 | 528.6 | 0.0004 | 0.003 |
| 9 | 489.936 | 532.054 | 489.9 | 532.1 | 0.0073 | 0.009 |
| 10 | 488.924 | 535.657 | 488.9 | 535.7 | 0.0049 | 0.008 |
| 11 | 488.065 | 539.394 | 488.1 | 539.4 | 0.0072 | 0.001 |
| 12 | 487.364 | 543.264 | 487.4 | 543.3 | 0.0074 | 0.007 |
| 13 | 486.822 | 547.270 | 486.8 | 547.3 | 0.0045 | 0.005 |
| 14 | 486.444 | 551.412 | 486.4 | 551.4 | 0.009 | 0.002 |
| 15 | 486.234 | 555.693 | 486.2 | 555.7 | 0.007 | 0.001 |

Table 3. Comparison of Simulink and Codesys results for the steering wheel in the opposite direction

| Steering Angle (Degree) | Codesys Results (rpm) | | Simulink Results (rpm) | | Error (%) | |
|-------------------------|-----------------------|---------|------------------------|-------|-----------|--------|
| | n_1 | n_2 | n_1 | n_2 | n_1 | n_2 |
| 0 | 505.538 | 505.538 | 505.5 | 505.5 | 0.008 | 0.007 |
| 1 | 507.958 | 503.251 | 508 | 503.3 | 0.008 | 0.009 |
| 2 | 510.510 | 501.099 | 510.5 | 501.1 | 0.002 | 0.0002 |
| 3 | 513.195 | 499.083 | 513.2 | 499.1 | 0.001 | 0.0034 |
| 4 | 516.01 | 497.204 | 516 | 497.2 | 0.002 | 0.0008 |
| 5 | 518.957 | 495.464 | 519 | 495.5 | 0.008 | 0.0073 |
| 6 | 522.035 | 493.865 | 522 | 493.9 | 0.007 | 0.0071 |
| 7 | 525.243 | 492.409 | 525.2 | 492.4 | 0.008 | 0.0018 |
| 8 | 528.583 | 491.098 | 528.6 | 491.1 | 0.003 | 0.0004 |
| 9 | 532.054 | 489.936 | 532.1 | 489.9 | 0.009 | 0.0073 |
| 10 | 535.657 | 488.924 | 535.7 | 488.9 | 0.008 | 0.0049 |
| 11 | 539.394 | 488.065 | 539.4 | 488.1 | 0.001 | 0.0072 |
| 12 | 543.264 | 487.364 | 543.3 | 487.4 | 0.007 | 0.0074 |
| 13 | 547.270 | 486.822 | 547.3 | 486.8 | 0.005 | 0.0045 |
| 14 | 551.412 | 486.444 | 551.4 | 486.4 | 0.002 | 0.009 |
| 15 | 555.693 | 486.234 | 555.7 | 486.2 | 0.001 | 0.007 |

According to the direction of the steering wheel, the speed values of front in-wheel motors obtained by Codesys and Simulink have been plotted in Fig. 5, 6, 7, and 8, respectively. As seen in the graphics, Codesys results are verified by Simulink results.

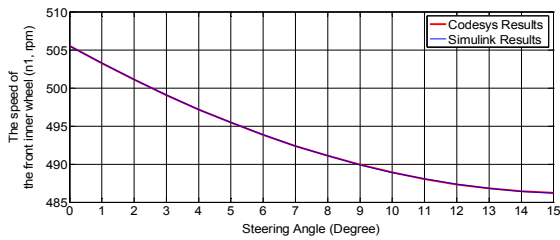

Fig. 5. Simulink and Codesys results of n_1

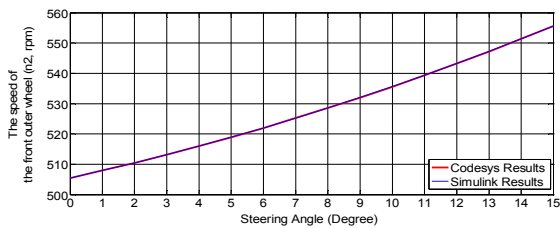

Fig. 6. Simulink and Codesys results of n_2

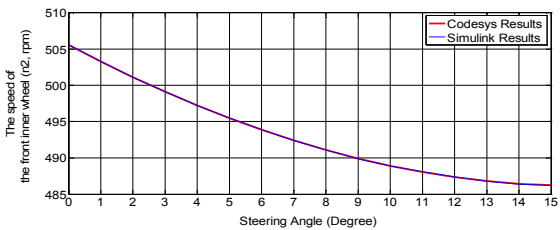

Fig. 7. Simulink and Codesys results of n_2 for steering wheel in the opposite direction

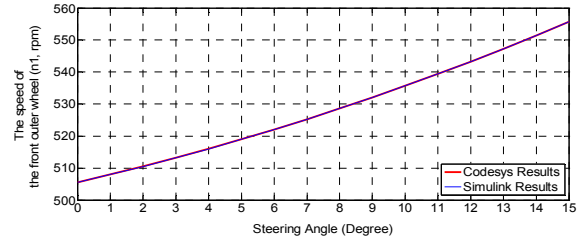

Fig. 8. Simulink and Codesys results of n_1 for steering wheel in the opposite direction

4. Conclusion

In this paper, an EDS for EVs with in-wheel motors has been modelled and simulated. While the EDS for rare wheels of the EV has been studied generally in the literature, an EDS for front wheels has been presented in this study. According to the steering angle and speed of the EV, the speeds of front in-wheel motors have been estimated by mathematical equations derived from Ackermann-Jeantand model using Codesys Software Package. Then, Matlab/Simulink modelling has been carried out using these equations. The speed values of the front wheels have been obtained by both Codesys and Simulink simulations for changing of the steering angle from 1° to 15° with a degree range. It has been observed that while the inner wheel speed of the EV decreases, the outer wheel speed increases by rising the steering angle value. The speeds of the front wheels estimated by Codesys Software Package have been also verified by comparing with Simulink results. Consequently, the simulation results are satisfactory.

5. References

- [1] M. Yildirim, M. Polat, H. Kurum, "A survey on comparison of electric motor types and drives used for electric vehicles", in *IEEE 16th International Power Electronics and Motion Control Conference and Exposition (PEMC)*, 2014, pp. 218-223.
- [2] R. N. Tuncay, O. Ustun, M. Yilmaz, C. Gokce, U. Karakaya, "Design and implementation of an electric drive system for in-wheel motor electric vehicle applications", in *IEEE Vehicle Power and Propulsion Conference (VPPC)*, 2011, pp. 1-6.
- [3] Y. E. Zhao, J. W. Zhang, and X. Q. Guan, "Modelling and simulation of the electronic differential system for an electric vehicle with two-motor-wheel drive", *International Journal of Vehicle Systems Modelling and Testing*, vol. 4, no. 1-2, pp. 1209-1214, 2009.
- [4] M. Jain and S. S. Williamson, "Suitability analysis of in-wheel motor direct drives for electric and hybrid electric vehicles", in *IEEE Electrical Power & Energy Conference (EPEC)*, 2009, pp. 1-5.
- [5] J. S. Lee, Y. J. Ryoo, Y. C. Lim, P. Freere, T. G. Kim, S. J. Son, and E. S. Kim, "A neural network model of electric differential system for electric vehicle", in *IEEE 26th Annual Conference of the Industrial Electronics Society (IECON)*, vol. 1, 2000, pp. 83-88.
- [6] A. Draou, "Electronic differential speed control for two in-wheels motors drive vehicle", in *IEEE Fourth International Conference on Power Engineering, Energy, and Electrical Drives (POWERENG)*, 2013, pp. 764-769.

- [7] D. Foito, G. Manuel, and V. F. Pires, "Road motion control electric vehicle with speed and torque observer", in *IEEE International Conference on New Concepts in Smart Cities: Fostering Public and Private Alliances (SmartMILE)*, 2013, pp. 1-6.
- [8] B. R. Munusamy, R. Balasharmila, and J. D. Weigl, "Design of rear wheel torque vectoring for dual motor electric drive system", in *IEEE Ninth International Conference on Ecological Vehicles and Renewable Energies (EVER)*, 2014, pp. 1-20.
- [9] X. Wu, Y. Li, and X. Min, "Speed following control for differential steering of 4WID electric vehicle", in *IEEE 2014-40th Annual Conference of the Industrial Electronics Society (IECON)*, 2014, pp. 3054-3059.
- [10] A. Haddoun, M. E. H. Benbouzid, D. Diallo, R. Abdessemed, J. Ghouili, and K. Srairi, "Modeling, analysis, and neural network control of an EV electrical differential", *IEEE Transactions on Industrial Electronics*, vol. 55, no. 6, pp. 2286-2294, 2008.
- [11] L. Zhai and S. Dong, "Electronic differential speed steering control for four in-wheel motors independent drive vehicle", in *IEEE 9th World Congress on Intelligent Control and Automation (WCICA)*, 2011, pp. 780-783.
- [12] R. C. B. Sampaio, A. C. Hernandez, V. D. V. M. Fernandes, M. Becker, and A. A. G. Siqueira, "A new control architecture for robust controllers in rear electric traction passenger HEVs", *IEEE Transactions on Vehicular Technology*, vol. 61, no. 8, pp. 3441-3453, 2012.
- [13] M. W. Choi, J. S. Park, B. S. Lee, and M. H. Lee, "The performance of independent wheels steering vehicle (4WS) applied Ackerman geometry", in *IEEE International Conference on Control, Automation and Systems (ICCAS)*, 2008, pp. 197-202.
- [14] H. Kahveci, H. İ. Okumus, and M. Ekici, "An electronic differential system using fuzzy logic speed controlled in-wheel brushless DC motors", in *IEEE Fourth International Conference on Power Engineering, Energy and Electrical Drives (POWERENG)*, 2013, pp. 881-885.
- [15] Y. Zhou, S. Li, X. Zhou, and Z. Fang, "The control strategy of electronic differential for EV with four in-wheel motors" in *IEEE Control and Decision Conference (CCDC)*, 2010, pp. 4190-4195.