

An Optimal Installation Strategy of Photovoltaic-Based DGs and Capacitors Considering Distributed VAR Support of Photovoltaic Converters

Tohid Sattarpour¹, Daryoush Nazarpour¹, and Sajjad Golshannavaz¹

¹Electrical Engineering Department, Urmia University, Urmia, Iran
t.sattarpour@urmia.ac.ir, d.nazarpour@urmia.ac.ir, s.golshannavaz.2015@ieee.org

Abstract

Recently, due to increased interest in low carbon energy supply, installation of renewable energy sources (RESs) appears to be a promising solution for generating clean and unlimited energy. The penetration of photovoltaics (PVs) in distribution networks would definitely affect the power system problems such as capacitor installation strategies. Therefore, an optimal procedure is proposed herein which investigates the simultaneous placement of PV-based distributed generations (DGs) and capacitors taking into account different load curves, electricity prices, and hourly photovoltaic power generation in a daily basis. Moreover, the seasonal changes in daily load and renewable generations have been also modeled as an impressive factor in the founded methodology. The optimization procedure is handled with genetic algorithm (GA) and tested on IEEE 69-bus radial distribution test system aiming at minimization of energy losses costs. Focusing on numerical studies, the distributed reactive support capability of PVs in altering the capacitor placement solutions has been discussed in depth to certify their substantial effect. The obtained results are encouraging.

1. Introduction

DGs are promising equipment that can support the emergent power grids due to their marvelous capabilities in improving the system reliability and facilitating the high penetration of renewable energy sources (RESs) [1]. The penetration of distributed generation (DG) units is increasing on power distribution networks across the world. Likewise, facing with the quick development of innovative technologies, some technical features such as power losses minimization as well as economic benefits such as reduction in long-term planning and short-term operational costs motivates the worldwide nations to cater the utilization of DGs in their distribution networks [2]. Thus, these units are now a motivating option for distribution network operators (DNOs) to meet the requirements of their customers [3]. The most common types of DGs are the conventional diesel-based and renewable-based DGs [4]. Renewable-based DGs like wind turbines (WTs) and photovoltaic (PV) modules which are depending on weather conditions are widely used in smart grid notions [5].

A high penetration of PV-based DGs on customer side of power systems yields in some advantages such as peak load shaving, power losses reduction, and so on [6]-[7]. On the other hand, due to the practical implementation of innovative technologies such as smart grid infrastructure and its control

capabilities, it has been made possible to install PVs in different operating modes such as variable power factor. This ability is in essence impressive for both active and reactive power support of PV modules to the network. Regarding the demand side of the power system, there are different types of consumers such as residential loads and also induction motors as the running horse of the industry which generally are demanding reactive power too. In this way, shunt capacitors are used to improve the reactive power provision and obviating some potent technical problems [8]-[11]. Thus, capacitors are supplemented at the end side of the system for power factor regulation, power loss reduction, and maintaining an acceptable voltage profile within permissible limits. However, attaining these benefits depends on the site, capacity, and number of the capacitors to be installed in the network.

The optimal placement of capacitors in distribution networks has been conducted with different objectives such as power loss reduction, system capacity release, and voltage profile improvement [12]-[13]. In [14], the author has proposed a general approach for concurrent allocation of capacitors and DGs in active distribution networks considering online reconfigurations. Authors in [15] have proposed a probabilistic modeling of PV modules and WT generation based on Monte Carlo simulation, Gram-Charlie, two point estimate and some other methods. They have shown the effect of uncertain and geographical-dependent behavior of WTs in active power losses reduction. Authors in [16] have presented an optimization strategy based on teaching learning algorithm to minimize the energy costs and active power losses by optimal placement of capacitors in radial distribution systems. As well, intelligent algorithms such as genetic algorithm (GA) have been successfully proposed for optimal placement of capacitors in distribution networks [17]. In [18], an optimal simultaneous placement of DGs and capacitors has been proposed for active power loss reduction in distribution networks. In this study, DGs have been applied assuming variable power factor in order to be apt for providing both active and reactive power.

Considering the smart grid practical implementations and the connection facilities of PV modules to the network, these units are equipped with power electronics-based power converters. The unique control capabilities of these converters yield in different operating modes such as interacting of both active and reactive power with the main network. Thus, this opportunity let us think about the distributed VAR support by PV modules and benefiting from this option in technical and economical improvement of the network. This feature would definitely affect the VAR supporting schemes such as optimal placement of capacitors by changing both the site and size of capacitors to be installed. Although a vast body of literature has

been conducted regarding PV modules optimal placement strategies, however, the distributed VAr support of PVs necessitates thinking of some new and efficient ones.

Hence, this paper aims at establishing an optimal placement strategy of capacitor banks and PV modules considering the reactive support of PVs in a concurrent manner intended for energy loss reduction. For the sake of simplicity, the proposed planning scheme is assessed in one year time horizon. However, a finer attention has been devoted to modeling the seasonal changes in daily load curves and geographical input data. Moreover, the hourly analysis of the problem has been conducted as well to result in a more precise evaluation of the planning problem. By determination of optimal sites for PV modules, the effect of this allocation in optimal placement of capacitors would be analyzed in depth. Specifically speaking, the distributed reactive support capability of PV modules in optimal capacitor placement has been highlighted in more details. The optimization procedure has been formulated as a non-linear problem (NLP) and tackled with GA seeking to minimize total energy losses cost. To investigate the validity of the proposed approach, the IEEE 69-bus radial distribution system has been considered as the test-bed. Different numerical scenarios have been devised and then evaluated to yield in a suitable judgment platform.

The remainder of this paper is organized as follows. Mathematical formulation of the optimization problem is presented in section 2. In the sequel, section 3 addresses the GA fundamentals and introduces the proposed chromosome for the problem. Afterwards, different scenarios have been devised and simulated to produce the numerical results as in section 4. Eventually, concluding remarks are presented in section 5.

2. Problem Statement and Mathematical Formulation

This section is devoted to present the mathematical formulation for optimal allocation of PV modules and capacitors. In the following subsections, assumptions, objective function considered to be optimized, and also running constraints are introduced respectively in depth.

2.1 Assumptions

The planning problem is solved under some effective assumptions as follows:

- Distribution network is assumed to be balanced.
- There is limited budget for placing of both PV modules and capacitors. Therefore, both the number and size of the PV modules and capacitors would be limited.
- PV modules are operated in power factors rather than unity allowing them to generate both active and reactive power.
- Different prices of energy losses are supposed during a day to bring about a more realistic study.

2.2 Objective Function

PV modules are considered to be installed at different buses injecting both active and reactive power to the network. As well, capacitors are installed at different buses injecting only reactive power to the network. Capacitors and PV systems, due to their capabilities, could be utilized to attain numerous objectives such as energy losses cost minimization, active power losses reduction, and voltage profile improvement. Therefore, the most

important purpose is to minimize the overall seasonal energy losses cost during the planning period. The established objective function is represented in (1):

$$\text{Minimize} \quad P_{loss}^{Total} = \frac{365}{4} \times \left[\left(\sum_{h=1}^{24} P_{loss_h}^{Spring} \times cost_h \right) + \left(\sum_{h=1}^{24} P_{loss_h}^{Summer} \times cost_h \right) + \left(\sum_{h=1}^{24} P_{loss_h}^{Autumn} \times cost_h \right) + \left(\sum_{h=1}^{24} P_{loss_h}^{Winter} \times cost_h \right) \right] \quad (1)$$

Where, $cost_h$ is the energy losses price at hour h , $P_{loss_h}^S$ is the total power loss of network at season s and hour h . The total active power loss in each season is calculated based on (2).

$$P_{loss_h}^S = \sum_k |I_k|^2 \times R_k \quad k \in \Omega_{Br} \quad (2)$$

Herein, R_k and I_k are respectively representing the resistance and current magnitude in k -th branch, and Ω_{Br} is denoting the set of branches, respectively. Note that, because of different load curves and solar radiation for each season, total power losses of the network at one specific hour of all season would not be similar. In this study, each year is separated into 4 seasons and 365 days where a usual day for each season contains 24 hours.

2.3 Constraints

The problem of optimal simultaneous allocation of capacitors and PV modules in the network is subjected to the following equality and inequality constraints.

2.3.1 Power Flow Equations:

The equality constraints (3) and (4) are taken for granting the governing of Kirchhoff's current and voltage equations in power flow procedure. The existing power flow equations are modified to include the effect of PV modules to generate both active and reactive power and capacitors to generate only reactive power to the network, as stated in equations (3) and (4).

$$P_{g_i}^h + P_{PV_i}^h - P_{L_i}^h = \sum_{j \in \Omega_i} P_{ij}^h(V_i^h, V_j^h, Y_{ij}^h, \theta_{ij}^h) \quad (3)$$

$$Q_{g_i}^h + Q_{PV_i}^h + Q_{Cap_i}^h - Q_{L_i}^h = \sum_{j \in \Omega_i} Q_{ij}^h(V_i^h, V_j^h, Y_{ij}^h, \theta_{ij}^h) \quad (4)$$

Where, $P_{PV_i}^h$ and $Q_{PV_i}^h$ are active and reactive power generation by PV module at bus i and hour h respectively. $Q_{Cap_i}^h$ is reactive power injection by capacitor at hour h . $P_{L_i}^h$ and $Q_{L_i}^h$ represent the active and reactive powers of distribution feeders at hour h . V^h indicates the bus voltage at hour h . Finally, Y_{ij}^h and θ_{ij}^h are respectively symbolizing the magnitude and phase angle of the feeder's admittance at hour h .

2.3.2 Voltage Magnitude Limits:

Suitable constraints are essential to guarantee the voltage magnitude to be kept at permissible ranges at each bus and each hour. The voltage magnitude for substation buses is maintained at 1 p.u.:

$$V_{\min} \leq |V_i| \leq V_{\max}, \quad (5)$$

$$|V_{i,s}| = 1 \text{ p.u.}, \quad (6)$$

Here, V_{\min} and V_{\max} are minimum and maximum limits of bus voltages respectively. Also, i is the index of buses and s is accounting for substation buses of the network.

2.3.4 Apparent Power Flow Limits for Feeders:

It is required to keep the apparent power flow for each feeder in its allowable range:

$$\sqrt{P_k^2 + Q_k^2} \leq S_k^{\max}, \quad k \in \Omega_{Br} \quad (7)$$

2.3.5 PV Modules Active and Reactive Power Generation:

The limited budget available for network operators may confine the total number and size of installed PV modules. Likewise, applying PV modules by power factors rather than unity makes them possible to generate both active and reactive power. These notations are considered through constraints (8)-(13) as follows:

$$\left[(P_{pv}^h)^2 + (Q_{pv}^h)^2 \right]^{1/2} \leq S_{pv}^{\max} \quad (8)$$

$$P_{pv}^h \leq P_{pv}^{\max} \quad (9)$$

$$Q_{pv}^h \leq Q_{pv}^{\max} \quad (10)$$

$$Q_{pv}^h = \tan(\cos^{-1}(PF_{pv}^h)) \times P_{pv}^h \quad (11)$$

$$PF_{pv}^h = \frac{P_{pv}^h}{(P_{pv}^h + Q_{pv}^h)^{1/2}} \quad (12)$$

$$N_{pv} = N_{pv}^{\max} \quad (13)$$

Here, p_{pv}^h and Q_{pv}^h are PV modules' active and reactive power generation at hour h , respectively. P_{pv}^{\max} and Q_{pv}^{\max} are the maximum limits for PV modules active and reactive power generation, respectively. S_{pv}^{\max} is the maximum apparent power limit for PV modules. Also, PF_{pv}^h represents the designated power factor of PV modules at each hour h .

2.4 Capacitors Reactive Power Injection:

Determination of installation buses for PV modules, itself will have a great influence on the optimal solutions for capacitors location. Therefore, it should be modeled as a part of optimization process. The maximum number of installed capacitors would be taken as N_{Cap}^{\max} . Moreover, each candidate bus that is selected as an optimal site of capacitors should satisfy the maximum amount of allowable reactive power injection during each percentage of peak loads at selected bus. The following constraints for each season are taken to be observed:

$$N_{Cap} = N_{Cap}^{\max} \quad (14)$$

$$Q_{Cap}^h \leq Q_{Cap}^{\max} \quad (15)$$

3. Optimization Technique based on Genetic Algorithm

One of the most influential parts in distribution system studies is to plan an appropriate solution scheme. As mentioned earlier, the established framework under study is a non-linear problem (NLP) which is solved using GA. As an intelligent search method, GA imitates the biological selection procedure. By this way, GA would be suitable to attentively analysis the search space and then find the ideal solutions. In [17], authors have made benefit of GA in capacitor placement problem. They have shown its superior performance compared to other meta-heuristic algorithms in terms of solution error. One of the key advantages of this algorithm originates from its multipoint search feature. Thus, it can produce a set of non-dominated solutions during the optimization. The tailored features have induced us benefitting from GA as the optimization engine herein. One of the main steps of the founded methodology includes the coding strategy of the proposed chromosome in GA which is shown in Fig. 1. As it is shown, at the outset, the initial population of possible solutions is generated. Then the available solutions are evaluated in order to optimize the objective function. This technique is known as evolution process implemented by specific operators namely crossover and mutation. As it is shown, crossover process produces new offspring that will replace some of the old individuals of the population. Also, the mutation operator involves selecting a specific element of the coded chromosome and altering its gens to a different one. To make it short, the most qualified parents would be more likely to last and copy their genes to following generations [18]-[19] and this cycle will direct GA to find the optimal solutions. As it is shown in Fig. 1, in this work, each chromosome contains two parts. The first part accounts for optimal PV modules placement and the second part accounts for optimal capacitors' site. Note that, this figure is demonstrating the GA procedures for a typical period of planning horizon.

4. Numerical Results and Discussion

4.1 Test System Specifications

As it is demonstrated in Fig. 2, the proposed framework has been tested on the well-known IEEE 69-bus radial distribution test system. The rated active and reactive power of each bus as well as feeders data are taken from [20]. Aggregated daily load curves with exact percentage of peak load for each hour of each season are displayed in Fig. 3. Considering the test system in its base structure, the total peak load of the network is equal with 3.8019 MW and 2.6941 MVAR. As it is clearly observed, bus 1 is connected to the sub-transmission network and is assumed as the substation. In this paper, the impact of allocating a PV module is studied through calculating the power generation of modules considering solar radiance for each time segment in planning period as shown in Fig. 4. As it is shown, there is no any power generation for some specific hours of a day.

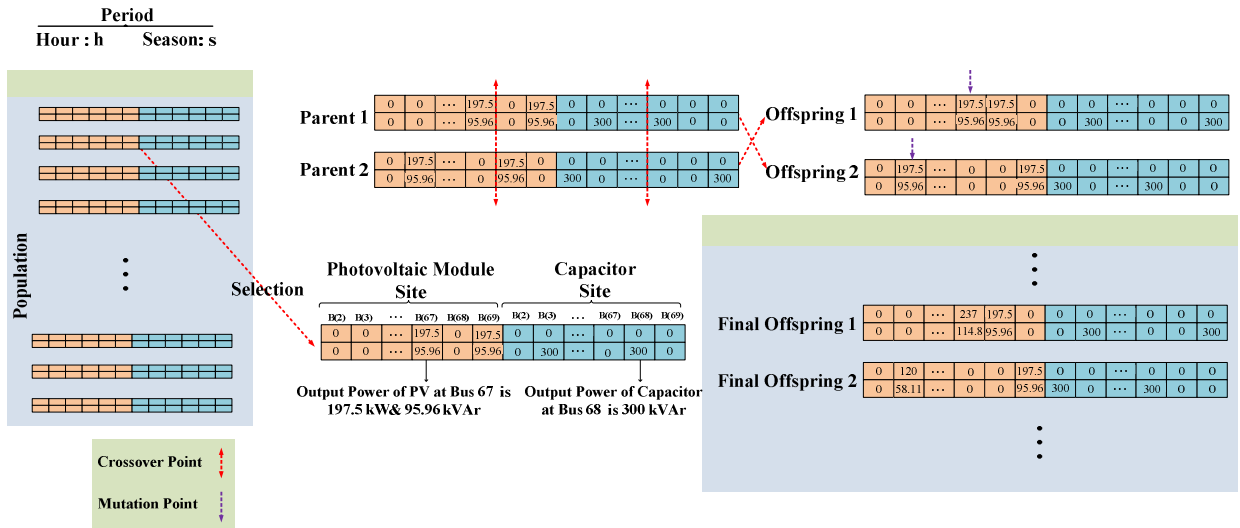

Fig. 1. Structure of the proposed chromosome.

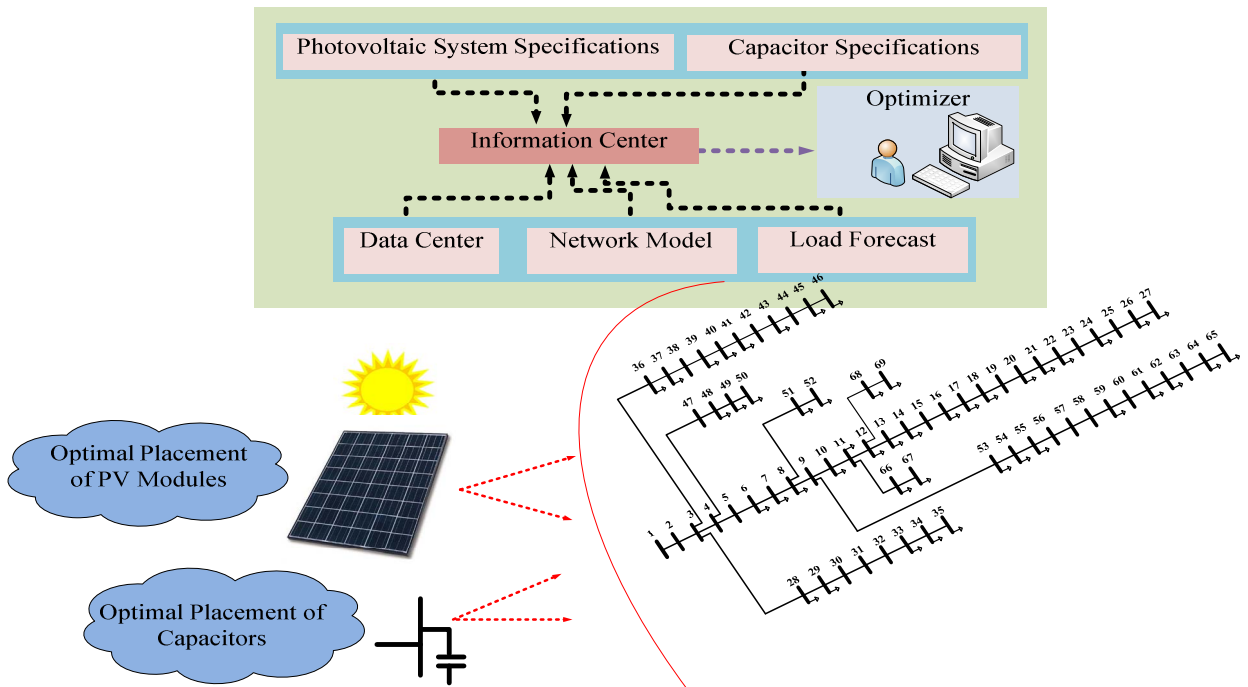

Fig. 2. Single line diagram of IEEE 69-bus test system.

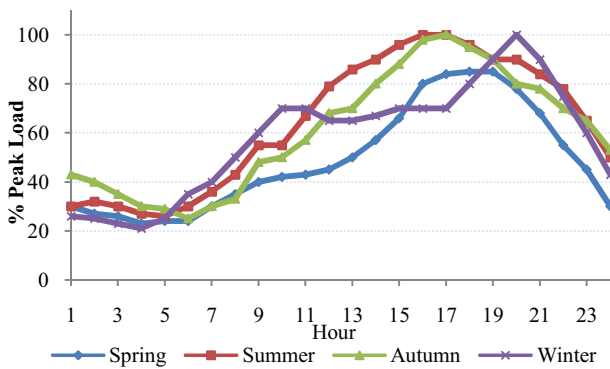

Fig. 3. Mean daily load curves for each season.

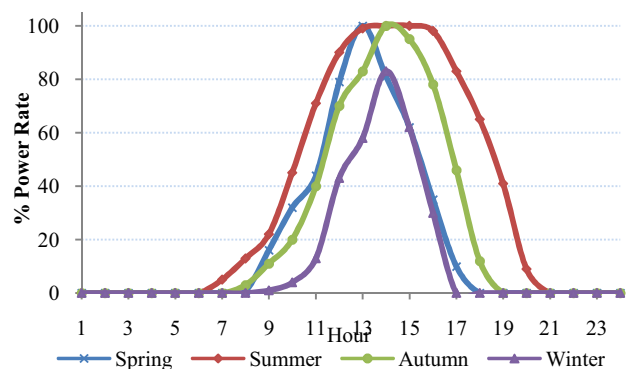

Fig. 4. Mean PV power generation during a day for each season.

In this study, PV modules and capacitors are assumed with 250 kW active power rate and 300 KVAR reactive power rate, respectively. With respect to designated constant power factor of 0.9, PV modules are allowable to operate with power factors of 0.9 and unity value. The maximum possible investment capital available for DNO limits the maximum number of PV modules and capacitors up to $N_{PV}^{max} = 2$, $N_{Cap}^{max} = 2$, respectively. The discrete electricity energy losses prices (\$/kWh) during the planning period are given in Fig. 5. As it can be observed, three different electricity prices have been assumed for three different intervals considering percentage of peak load.

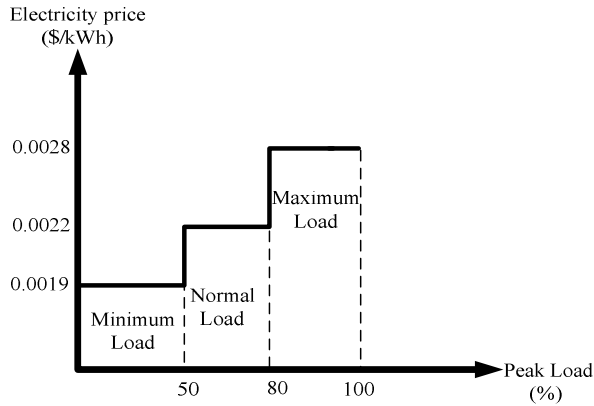

Fig. 5. Electricity price curve.

Regarding the GA operators, several distinct runs with different values for crossover and mutation rates have been conducted. Even though there were not so remarkable differences, the best results are obtained with population size of 60, recombination rate equal with 0.4 and mutation rate of 0.03 respectively.

4.2 Multi-Scenario Optimal Allocation of PV Modules and Capacitors

To present a comprehensive analysis, five different scenarios have been planned as stated in Table. 1.

Base plan represents the basic structure of the test case without considering any capacitors and PV modules. In the following subsections, simulation results are obtained for each scenario and discussed in depth.

Table 1. Investigated numerical scenarios.

Scenarios	Placement Strategy		
	PV modules	Capacitors	PVs converter power factor
Scenario 1 (Base Plan)	-	-	-
Scenario 2	-	✓	-
Scenario 3	✓	-	1
Scenario 4	✓	✓	1
Scenario 5	✓	✓	0.9

4.3 Discussion on Numerical Results

Table. 2 provides the obtained numerical results for test system in different scenarios regarding each season as the time horizon. For each season, the optimal allocation of capacitors and also the optimal installation sites of PV modules have been determined. First scenario is the base plan without any capacitors and PV modules allocation. As shown, in this scenario energy losses cost is different during seasons because of different load curves and PV modules power generation. For the second scenario, two capacitors allocation could reduce the seasonal energy losses and have remarkable effects on total energy losses during a year. Also, the third scenario denotes the optimum placement of two PV modules in the test system. As shown in this scenario, PV modules placement at buses 61 and 64 could decrease the total energy losses from 17876.4\$ to 15471.0\$. Also, as it is obvious, considering PV modules in fourth scenario would affect the optimal placement of capacitors to be installed and could decrease the seasonal energy losses and total energy losses during the planning period. In the fifth scenario, by considering simultaneous placement of two PV modules with 0.9 power factor and two capacitor units, there has been 38.98% reduction in total energy losses cost. These notable triumphs with respect to other scenarios are due to applying PV modules providing reactive power support too. It is worth noting that the concurrent placement of capacitors with PV units not only affects the seasonal and total energy losses, but also change the placement of capacitors and PV units too. The optimal results obtained for the test system in different scenarios has been illustrated in Fig. 6 visually.

Table 2. Optimal seasonal results of IEEE 69-bus test system.

Scenarios	Placement Strategy						Total Energy Losses Cost (\$)	Saving (%)
	Energy Losses Cost (\$)				Placement Results			
	Spring	Summer	Autumn	Winter	PV modules	Capacitors		
Scenario 1 (Base plan)	2792.0	5930.3	4888.4	4265.7	-	-	17876.4	-
Scenario 2	2057.1	4461.3	3643.8	3156.6	-	Bus 61, Bus 62	13318.8	25.49
Scenario 3	2516.3	4734.6	4212.8	4007.3	Bus 61, Bus 64	-	15471.0	13.45
Scenario 4	1862.9	3499.1	3128.9	3003.8	Bus 59, Bus 62	Bus 59, Bus 65	11494.7	35.70
Scenario 5	1826.6	3200.5	2955.2	2926.2	Bus 61, Bus 62	Bus 62, Bus 65	10908.5	38.98

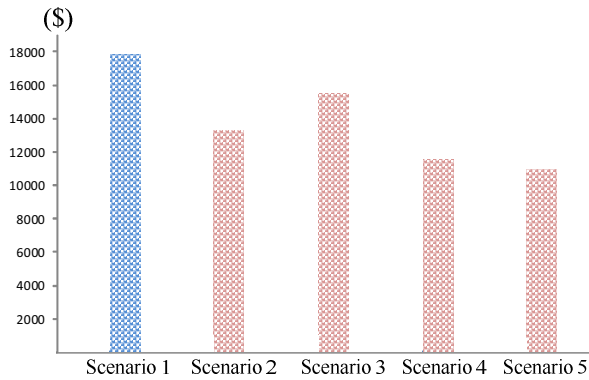

Fig. 6. Total energy losses cost for each scenario during a year.

5. Conclusion

In this paper, by presenting an efficient mathematical formulation, simultaneous allocation of capacitors and PV-based DGs have been modeled and tackled based on GA. Different numerical scenarios have been conducted on IEEE-69 bus test system. In each season, the proposed approach exploited different daily load curves, different energy prices in peak loads, and hourly mean-power generation of PV units. It was shown that applying PV units for supporting reactive power along with capacitor placement would have a considerable effect on total energy losses cost minimization. This feature of PV modules has resulted in change of the installation sites and size of capacitors. Consequently, it can be a supporting option for DNOs to consider the PV-based DGs with variable power factor capable of providing both active and reactive power in expansion planning studies such as optimal siting and sizing issues in future smart distribution systems.

6. References

- [1] M.M. Aman, G.B. Jasmon, A.H.A. Bakar, and H. Mokhlis, "A New Approach for Optimum DG Placement and Sizing Based on Voltage Stability Maximization and Minimization of Power Losses", *Energy Conversion and Management*, vol. 70, pp. 202-210, 2013.
- [2] T. Sattarpour, and D. Nazarpour, "Assessing the Impact of Size and Site of DGs and SMs in Active Distribution Networks for Energy Losses Cost", *International Journal of Engineering (IJE) Transactions A: Basics*, vol. 28, no. 7, July 2015.
- [3] Z. Hu, and F. Li, "Cost-Benefit Analyses of Active Distribution Network Management, Part I: Annual Benefit Analysis", *IEEE Transactions on Smart Grid*, vol. 3, no. 3, pp. 1067-1074, 2012.
- [4] A. Zakariazadeh, S. Jadid, and P. Siano, "Smart Microgrid Energy and Reserve Scheduling with Demand Response Using Stochastic Optimization", *Electrical Power and Energy Systems*, vol. 63, pp. 523-533, 2014.
- [5] T. Niknam, F. Golestaneh, and A. Malekpour, "Probabilistic Energy and Operation Management of a Microgrid Containing Wind/ Photovoltaic/ Fuel Cell Generation and Energy Storage Devices Based on Point Estimate Method and Self-adaptive Gravitational Search Algorithm", *Energy*, vol. 43, pp. 427-437, 2012.
- [6] K. Kuroda, H. Magori, D. Kobayashi, T. Ichimura and R. Yokoyama, "An Evaluation Method for the Impact of PV Installations into Distribution Systems", *IEEE Innovative Smart Grid Technologies-Asia (ISGT ASIA)*, Japan, 2014.
- [7] A. Zakariazadeh, S. Jadid, and P. Siano, "Economic Environmental Energy and Reserve Scheduling of Smart Distribution Systems: A Multiobjective Mathematical Programming Approach", *Energy Conversion and Management*, vol. 78, pp. 151-164, 2014.
- [8] S. Gopiya Naik, D.K. Khatod, and M.P. Sharma, "Optimal Allocation of Combined DG and Capacitor for Real Power Loss Minimization in Distribution Networks", *Electrical Power and Energy Systems*, vol. 53, pp. 967-973, 2013.
- [9] G. Levitin, A. Kalyuzhny, A. Shenkman, and M. Chertkov, "Optimal Capacitor Allocation in Distribution Systems Using a Genetic Algorithm and a Fast Energy Loss Computation Technique", *IEEE Transactions on Power Delivery*, vol. 15, no. 2, April 2000.
- [9] S. Ganguly, N. C. Sahoo, and D. Das, "Multi-objective Planning of Electrical Distribution Systems Incorporating Shunt Capacitor Banks", *International Conference on Energy, Automation, and Signal (ICEAS)*, pp. 1-6, 2011.
- [11] M. H. Dideban, N. Ghadimi, M. B. Ahmadi, and M. Karimi, "Optimal Location and Sizing of Shunt Capacitors in Distribution Systems by Considering Different Load Scenarios", *J Electr Eng Technol*, vol. 8, no. 5, pp. 1012-1020, 2013.
- [12] J. Federico, V. González, C. Lyra, and F. L. Usberti, "A Pseudo-Polynomial Algorithm for Optimal Capacitor Placement on Electric Power Distribution Networks", *European Journal of Operational Research*, vol. 222, pp. 149-156, 2012.
- [13] V. Farahani, S. H. Hesamedin Sadeghi, H. Askarian Abyaneh, S. M. Mousavi Agah, and K. Mazlumi, "Energy Loss Reduction by Conductor Replacement and Capacitor Placement in Distribution Systems", *IEEE Transactions on Power Systems*, 2013.
- [14] S. Golshannavaz, "Optimal Simultaneous Siting and Sizing of DGs and Capacitors Considering Reconfiguration in Smart Automated Distribution Systems", *J Intelligent Fuzzy Syst*, vol. 27, no. 4, pp. 1719-1729, 2014.
- [15] A. Soroudi, M. Aien, and M. Ehsan, "A Probabilistic Modeling of Photo Voltaic Modules and Wind Power Generation Impact on Distribution Networks", *IEEE Systems Journal*, vol. 6, no. 2, June 2012.
- [16] S. Sultana, and P. Kumar Roy, "Optimal Capacitor Placement in Radial Distribution Systems Using Teaching Learning Based Optimization", *Electrical Power and Energy Systems*, vol. 54, pp. 387-398, 2014.
- [17] R. A. Gallego, A. J. Monticelli, and R. Romero, "Optimal Capacitor Placement in Radial Distribution Networks", *IEEE Transactions on Power Systems*, vol. 16, no. 4, 2001.
- [18] T. Sattarpour, D. Nazarpour, S. Golshannavaz, and P. Siano "An Optimal Procedure for Sizing and Siting of DGs and Smart Meters in Active Distribution Networks Considering Loss Reduction", *J Electr Eng Technol*, vol. 10, no. 3, pp. 804-811, 2015.
- [19] H. E.A. Talaat, and E. Al-Amr, "Optimal Allocation and Sizing of Distributed Generation in Distribution Networks Using Genetic Algorithms", *11th International Conference on Electrical Power Quality and Utilisation*, pp. 1-6, 2011.
- [20] S. Chandramohan, N. Atturulu, R.P. Kumudini Devi, and B. Venkatesh, "Operating Cost Minimization of a Radial Distribution System in a Deregulated Electricity Market Through Reconfiguration Using NSGA Method", *Electrical Power and Energy Systems*, vol. 32, pp. 126-132, 2010.