

Low Input Impedance Current Differencing Unit for Current Mode Active Devices Improved by Positive Feedback and ZC-CDBA Filter Application

Ersin Alaybeyoğlu¹, Arda Güney², Mustafa Altun¹, and Hakan Kuntman¹

¹Istanbul Technical University, Department of Electronics and Communication Engineering, Istanbul, Turkey
ealaybeyoglu@itu.edu.tr, altunmus@itu.edu.tr, kuntman@itu.edu.tr

²Yildiz Technical University, Department of Electronics and Communication Engineering, Istanbul, Turkey
aguney@yildiz.edu.tr

Abstract

In current mode analog circuit design, current differencing unit is widely used at the input stage of the current mode analog building blocks. The low input impedance current differencing unit is excellent for current mode circuit realization. In the current study, the positive feedback is used for reducing the input impedance of current differencing unit. The proposed current differencing unit is tested at the input stage of the ZC-CDBA (Z copy current differencing buffered amplifier) recently published as a current mode analog building block. The proposed circuit for ZC-CDBA is verified with the KHN analog filter application. The circuit simulations are verified by using BSIM3 0.18 μm level-7 SPICE parameters.

1. Introduction

Analog signal processing systems can be examined in two main groups as voltage-mode or current-mode circuits, in terms of operating principles. The voltage-mode circuits' input signal and the output signal are voltage. The input signal and output signal are current in current mode circuits. Analog building block based on the current-mode, such as current conveyors, current operational amplifiers seem to have a better signal dynamic range and closed-loop bandwidth performance than conventional counterpart voltage mode circuits [1-11].

ZC-CDBA (Z Copy Current Differencing Buffered Amplifier) and ZC-CDTA (Z Copy Current Differencing Transconductance Amplifier) are recently recommended as current mode analog building blocks by D. Birolek [3]. The ZC-CDBA and ZC-ZDTA increase the universality of the CDBA and CDTA, where a copy of the current through the Z terminal is available at the Z-Copy terminal. The classical current mirror is used to copy the Z terminal output terminal current. The third generation current conveyor is also applicable to duplicate the Z terminal output current [3].

The input stage of these current mode elements consists of current differencing unit. The P and N input terminal impedances of the current differencing unit must be ideally zero. In the current study, the input impedance of the current differencing unit block is decreased by positive feedback technique. The Z-Copy Current Differencing Buffered Amplifier also has two high impedance Z, Z-copy terminals and one low impedance W terminal.

In the last section, a current mode ZC-CDBA filter application is presented. The proposed filter contains two ZC-CDBAs, two grounded capacitors and two resistors. The proposed filter has also low passive sensitivities.

Low input impedance current differencing unit structures are useful for small value resistors in current mode implementations. Application circuits designed by exploiting smaller value resistors allow the design of integrated circuit structures occupying less area.

2. Reduction method for input impedance

The engineer solves problems with the most accurate approach. In electronic circuits, the voltage source internal impedance is ideally zero and the current source internal impedance is ideally infinite. In reality, it is impossible to realize infinite internal impedance for current sources.

Designers who use building blocks in order to obtain impedance values close to ideal, benefit from negative or positive feedback. In this work, positive feedback is used to reduce the input impedance of the current differencing unit. Also, comparison of negative and positive feedback is given. Fig. 1, 2 and 3 show a system without feedback, the positive feedback and the negative feedback, respectively. Z_i , Z_p and Z_n indicates the internal impedance value of the system without feedback, positive feedback and negative feedback, respectively.

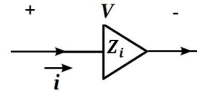

Fig. 1. A system without feedback.

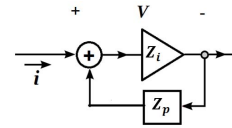

Fig. 2. The positive feedback system.

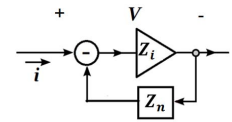

Fig. 3. The negative feedback system.

The internal impedance value of a general system is the ratio of the voltage over the system to the current which flows inside of the system. The internal impedance for Fig. 1 is given in Equation 1.

$$\frac{V}{i} = Z_i \quad (1)$$

The internal impedance seen from the Fig. 2 with positive feedback system is shown in Equation 2.

$$\frac{V}{i} = \left\{ 1 - \frac{Z_p}{Z_i} \right\} Z_i \quad (2)$$

The impedance value is reduced by the ratio of Z_p/Z_i . The ratio of the Z_p/Z_i must be selected lower than unity for positive impedance values. The negative impedance values can also be obtained by using positive feedback. The internal impedance seen from the Fig. 3 with negative feedback system is shown in Equation 3.

$$\frac{V}{i} = \left\{ 1 + \frac{Z_n}{Z_i} \right\} Z_i \quad (3)$$

It is obviously seen from Equation 2 and 3, the positive feedback system decreases the input impedance more than the negative feedback system.

3. ZC-CDBA CMOS structure

The CMOS structure of the ZC-CDBA is shown in Fig. 4. The equation matrix of the ZC-CDBA is given in Equation 4.

M1-M16 transistors belong to the current differencing unit. M21-M28 transistors are the voltage buffer's transistors. M17-M20 transistors are used to copy the current of Z terminal. The classical current mirror structure consists of M17-M20 transistors.

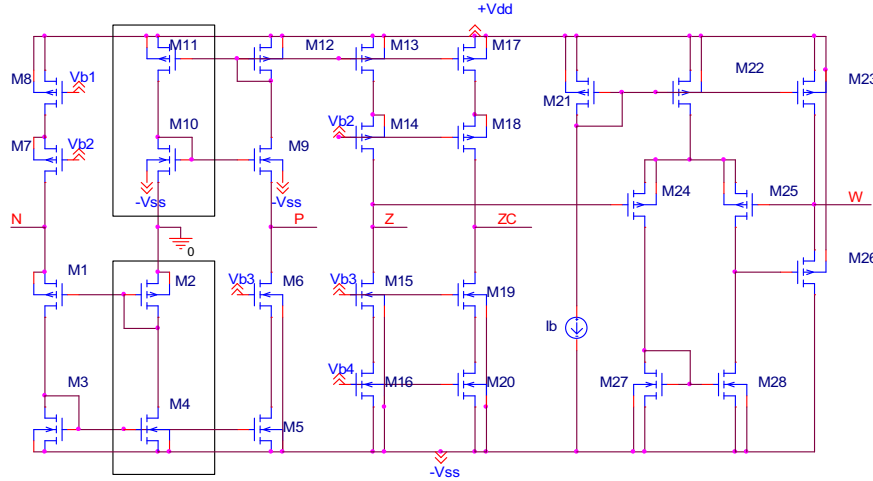

Fig. 4. ZC-CDBA CMOS Realization.

The positive feedback transistors to reduce the P terminal input resistance are M10 and M11. The positive feedback transistors to reduce the N terminal input resistance are M2 and M4. The input terminal impedances formulas are given in Equations 5 and 6 [6, 9].

$$\begin{pmatrix} i_z \\ i_{zc} \\ v_w \\ v_p \\ v_n \end{pmatrix} = \begin{pmatrix} 0 & 0 & 1 & -1 & 0 \\ 0 & 0 & 0 & 0 & 1 \\ 1 & 0 & 0 & 0 & 0 \\ 0 & 0 & 0 & 0 & 0 \\ 0 & 0 & 0 & 0 & 0 \end{pmatrix} \begin{pmatrix} v_z \\ i_w \\ i_p \\ i_n \\ i_z \end{pmatrix} \quad (4)$$

$$r_{in-} \approx \frac{1}{g_{m1}g_{m3}} \left\{ (g_{ds1} + g_{m3} + g_{ds3}) - \frac{g_{m1}g_{m4}}{g_{ds4} + g_{m2} + g_{ds2}} \right\} \quad (5)$$

$$r_{in+} \approx \frac{1}{g_{m9}g_{m12}} \left\{ (g_{ds9} + g_{m12} + g_{ds12}) - \frac{g_{m9}g_{m11}}{g_{ds11} + g_{m10} + g_{ds10}} \right\} \quad (6)$$

The input impedances of the P and N terminal are given in Fig. 5, 6, respectively. The input impedances compared with [7, 10] are approximately zero. The effect of the M2 and M4

transistors to the N terminal input impedance is given in Fig. 7. The phase margins show that the real part of the impedances are positive.

The effect of the M10 and M11 transistors to the P terminal input impedance is also given in Fig. 8. The desired input impedance level can be obtained by changing these transistors W/L ratios.

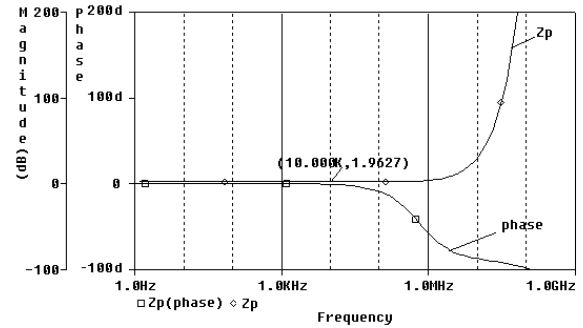

Fig. 5. P terminal input impedance.

The biasing V_{b1} , V_{b2} , V_{b3} and V_{b4} voltages are selected as 300mV, -400mV, 100mV and 300mV, respectively. The I_b current is selected 30 μ A.

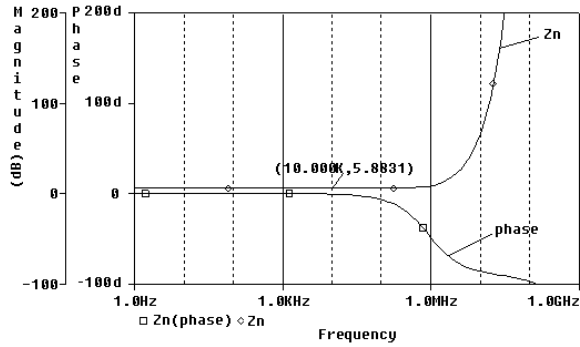

Fig. 6. N terminal input impedance.

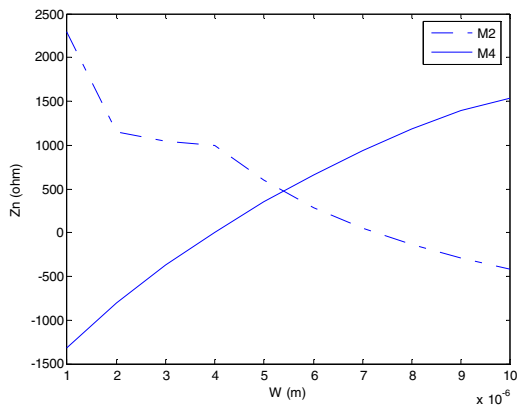

Fig. 7. The effect of the M2 and M4 transistors to the N terminal input impedance.

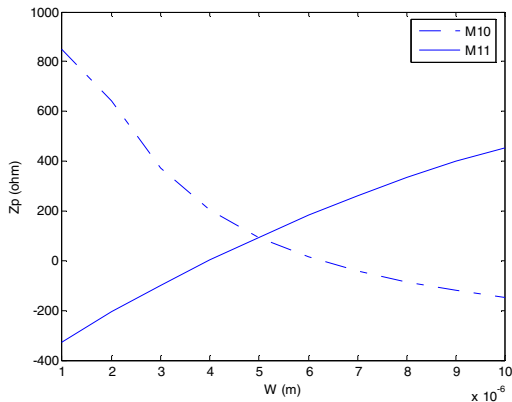

Fig. 8. The effect of the M10 and M11 transistors to the P terminal input impedance.

From Fig. 7, it can be easily observed that the input impedance is reduced by increasing the width of M2 and by decreasing the width of M4.

From Fig. 8, the low input impedance is improved by increasing the width of M10 and by reducing the width of M11.

The change of Z terminal current according to the P terminal current of the ZC-CDBA CMOS realization is given in Fig. 9. The Z terminal current dynamic range was observed between 30 μ A, -30 μ A.

The Z terminal output impedance, the change of W terminal voltage according to the Z terminal voltage and the output impedance of W terminal of the ZC-CDBA CMOS realization are given in Fig. 10, 11, 12, respectively. The output impedance at Z terminal was found 1.15M Ω . The Z terminal output impedance value is enough to drive the load of our application. The W terminal voltage dynamic range was observed between 275mV, -275mV. The W terminal output impedance was found 601.4 Ω .

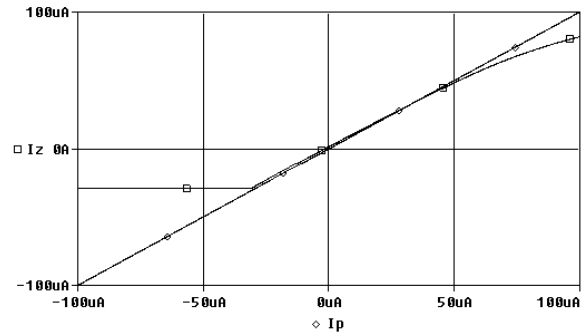

Fig. 9. The change of Z terminal current according to the P terminal current.

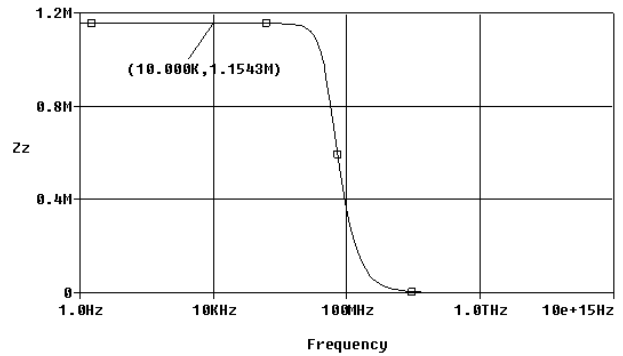

Fig. 10. The Z terminal output impedance.

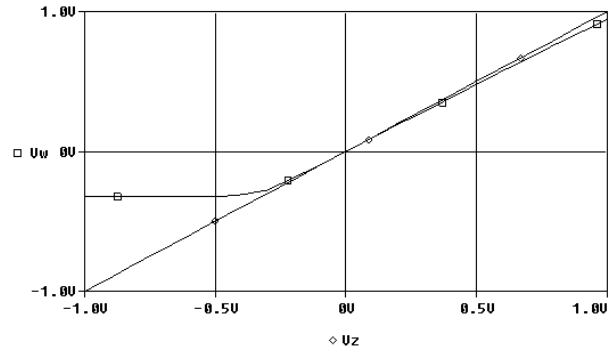

Fig. 11. The change of W terminal voltage according to the Z terminal voltage.

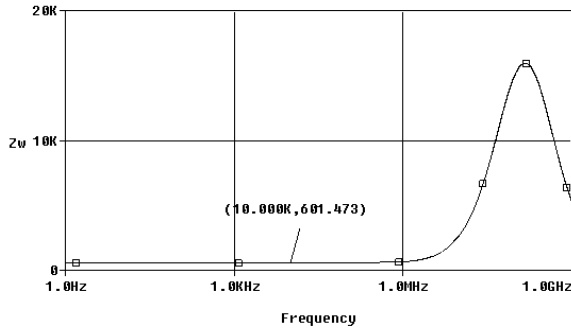

Fig. 12. The output Impedance of W terminal.

The performance characteristics of the ZC-CDBA CMOS structure are seen in Table 1. The sizes of the transistors are shown in Table 2.

Table 1. ZC-CDBA simulation results.

Power Supply	$\pm 0.9V$
Z terminal current dynamic range	$-30\mu A \leq I_z \leq 30\mu A$
W terminal voltage dynamic range	$-275mV \leq V_w \leq 275mV$
Iz/In (-3dB) bandwidth	481.674MHz
Iz/Ip (-3dB) bandwidth	674.945MHz
P terminal input impedance	1.9627 Ω
P terminal phase margin	47.76 $^\circ$
N terminal input impedance	5.8831 Ω
N terminal phase margin	57.50 $^\circ$
W terminal output impedance	601.473 Ω
Z terminal output impedance	1.1543M Ω
Vw/Vz (-3dB) bandwidth	67.108MHz
Power Consumption	313.66 μW

Table 2. ZC-CDBA transistors sizes.

Transistors	(W/L)
M1,M9	12 μ /0.36 μ
M2	7.2 μ /0.36 μ
M10	6.2 μ /0.36 μ
M4	4 μ /0.54 μ
M3,M5,M6,M7,M8,M11,M12,M13,M14,M15, M17,M18,M19	4 μ /0.36 μ
M16,M20	10 μ /0.36 μ
M21	36 μ /0.36 μ
M26	72 μ /0.36 μ
M22, M23, M24, M25, M27, M28	3.6 μ /0.36 μ

4. ZC-CDBA application circuit

KHN filter structure is one of the widely used filter structure in analog signal processing. KHN filter is proposed by Kerwin, Huelsman, Newcomb using state-variable synthesis in 1967. It is also produced commercially.

The most important characteristic of the KHN filter transfer function is the adequacy for different type of filter implementation (band pass, high pass, low pass) at the same time. An another important property of KHN filter is the conformity for low sensitivity realization.

The application circuit is given in Fig. 13. The structure of the KHN filter has two band pass filter sections, two high pass filter sections and one low pass filter section. One of the high pass filter section has high impedance. The capacitors C_1 and C_2 are 0.56pF. The resistors R_1 and R_2 are 20k Ω .

The filter output of the application circuit with ideal characteristics and the total harmonic distortion for input signal at 10MHz center frequency. are given in Fig. 14, 15, respectively.

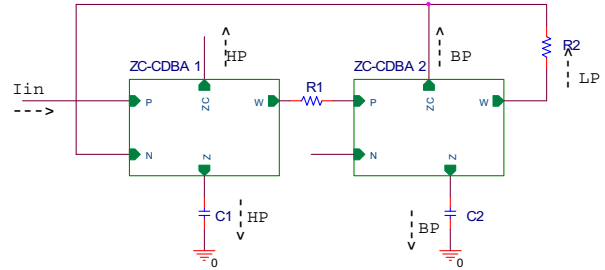

Fig. 13. ZC-CDBA filter application [5].

The proposed filter characteristics are in good agreement with the ideal characteristics of the low pass, band pass and high pass filter outputs as seen from Fig. 14.

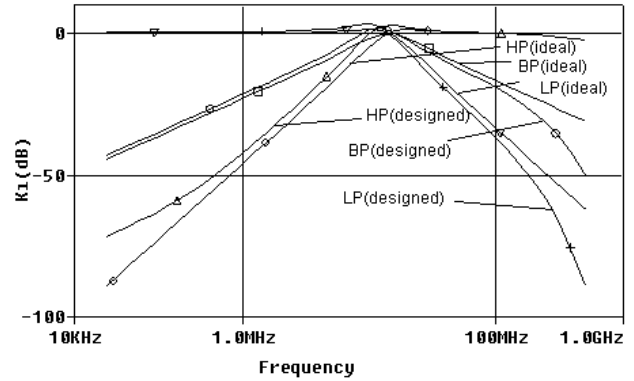

Fig. 14. ZC-CDBA filter simulation results.

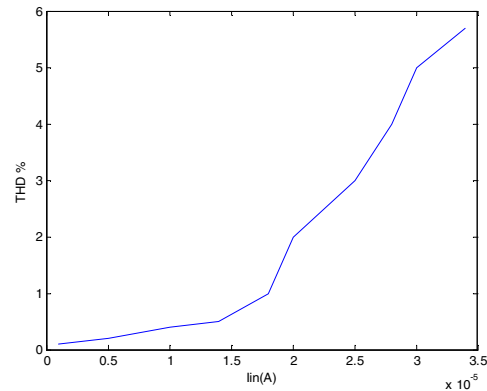

Fig. 15. The total harmonic distortion for input signal at 10MHz center frequency.

The high-pass, band-pass, low-pass filter transfer function, the pole angular frequency ω_0 and the quality factor Q are given in Equation 7, 8, 9, 10, 11, respectively [5, 8].

$$\frac{I_{HP}}{I_{IN}} = \frac{s^2}{s^2 + s \frac{G_1}{C_1} + \frac{G_1 G_2}{C_1 C_2}} \quad (7)$$

$$\frac{I_{BP}}{I_{IN}} = \frac{s \frac{G_1}{C_1}}{s^2 + s \frac{G_1}{C_1} + \frac{G_1 G_2}{C_1 C_2}} \quad (8)$$

$$\frac{I_{LP}}{I_{IN}} = \frac{\frac{G_1 G_2}{C_1 C_2}}{s^2 + s \frac{G_1}{C_1} + \frac{G_1 G_2}{C_1 C_2}} \quad (9)$$

$$\omega_0 = \sqrt{\frac{G_1 G_2}{C_1 C_2}} \quad (10)$$

$$Q = \sqrt{\frac{G_2 C_1}{G_1 C_2}} \quad (11)$$

Sensitivity analyses of the proposed filter with respect to active and passive components yield the following Equation 12, 13, respectively [5, 8].

$$S_{G_1}^{W_0} = S_{G_2}^{W_0} = -S_{C_1}^{W_0} = -S_{C_2}^{W_0} = 0.5 \quad (12)$$

$$S_{G_2}^Q = S_{C_1}^Q = -S_{G_1}^Q = -S_{C_2}^Q = 0.5 \quad (13)$$

5. Conclusion

A low input impedance current differencing unit was developed by positive feedback for current mode analog building block input stages. The importance of the low input impedance and the method for reducing input impedance were investigated. The KHN filter application based on Z-Copy Current Differencing Buffered Amplifier was presented. The

performance of ZC-CDBA was verified with the PSPICE BSIM3 0.18 μm level-7 SPICE parameters.

6. References

- [1] C. Toumazou, F. Lidjey, D. Haigh, Analog IC Design: The Current-Mode Approach, Exeter, UK, Peter Peregrinus, 1990.
- [2] B. Wilson, "Trend in current conveyor and current-mode amplifier design," Int. J. Electron., Vol. 23, pp. 573-583, 1992.
- [3] Biolek D., Senani R., Biolková V., Kolka Z., "Active Elements for Analog Signal Processing: Classification, Review, and New Proposals", RADIOENGINEERING, VOL. 17, NO. 4, , pp.15-32. DECEMBER 2008.
- [4] Acar C, Ozoguz S. A versatile building block: current differencing buffered amplifier suitable for analog signal processing filters. Microelectron J 1999;30:157-60.
- [5] E. Alaybeyoglu, A. Güney, H. Kuntman, 'A New CMOS ZC-CDBA Realization and Its New Filter Applications', Proc. of EUROCON 2013, Zagreb, Croatia.
- [6] M. Altun and H. Kuntman, 'Design of a Fully Differential Current Mode Operational Amplifier with Improved Input-Output Impedances and Its Filter Applications', AEU: International Journal of Electronics and Communications, Vol.62, NO. 3, 239-244, 2008.
- [7] Kacar, F., Kuntman, H. "A New Improved CMOS Realization of CDTA and Its Filter Application", TJEECS: Turkish Journal of Electrical Engineering & Computer Sciences, Vol.19, No.4, 631-642, 2011.
- [8] E. Alaybeyoglu, Analog circuit design with new active circuit components, M.Sc. Thesis, Istanbul Technical University, Istanbul, Graduate School of Science Engineering and Technology, Turkey, 2013.
- [9] M. Altun, Akım modlu işlemsel kuvvetlendirici tasarımı ve uygulamaları, M.Sc Thesis, İstanbul Technical University, Institute of Science and Technology, Turkey, 2007.
- [10] Uygur A., Kuntman H., 'Seventh order elliptic video filter with 0.1dB pass band ripple employed CMOS CDTAs', AEU: International Journal of Electronics and Communications, Vol.61, 320-328, 2007.
- [11] Dalibor Biolek, Josef Bajer, Viera Biolková, Zdeněk Kolka, Michal Kubíček, 'Z Copy - Controlled Gain - Current Differencing Buffered Amplifier and its applications' Int. Journal of Circuit Theory and Applications, vol. 39, no. 3, pp. 257-274, 2011.