

The Hybrid System for Education & Project Development

Bualoti R., Veislari K.

Electrical Engineering Faculty
Polytechnic University of Tirana - Albania
E-Mail: bualoti@uptal.tirana.al

Abstract - This paper describes the use of hybrid system both for education and project development. In education, the hybrid system is structured for experiments to support lecture presentations, while in project development the hybrid system is dedicated to a general engineering use or to a specific aspect of electric power system. A hybrid system that include the analogue computer GP-10 and digital computer (PC) IBM PC, AT, and compatible for research, development and education is used. An example, of the hybrid system use for analyse of automatic voltage control of generator of hydropower plant in Fierza (Albania) is presented. The priority of hybrid system as the laboratory equipment for hardware testing and development requirements is presented.

Key words: Analogue simulation, Hybrid simulation, Power system simulation, Automatic control.

The analogue and digital simulators complement each other and a perfect system analysis can be realised by two methods [1]. Once the analogue-to-digital and digital-to-analogue interface hardware and software are available, the hybrid simulation realises the detail analysis to be made in the analogue part, while the rest to be studied in the digital part. The hybrid simulation has the potential in building a large scale real-time simulator [7]. The hybrid system is necessary laboratory equipment for hardware testing and development requirements.

Control system designs, especially microprocessor based ones, need laboratory development. For testing, the analogue computer is as handy an instrument as a control engineer could have[3]. Its functions are:

- *Simulator of Systems to be Controlled.* The electrical analogues of physical models, analogue computer simulations offer realistic representations of processes and mechanisms to be controlled.
- *Programmable Linear Circuits Manifold.* The analogue computer patch panels offer the only formal means of programming linear signal processing, interface and control circuits.

Analogue computers in controls laboratory will likely support one of the following [4]:

- *Project Development,* where laboratory apparatus is dedicated to a specific project, remaining intact until its completion.
- *General Development,* where the apparatus is selected and organised for general engineering use.
- *Education,* where workstations are structured for experiments to support lecture presentations

The configuration workstation of fig.1 is suggested for purpose of research, development and education.

INTRODUCTION

The specific features in hybrid system are the analogue and digital natures of signals. As the electrical analogues of real systems, the analogue computer simulation produces the same continuous variables as those found in natural environments. On the other hands, digital computer acquires the signals and elaborates them using powerful software.

At some point a digital method will be limited because of excessive sampling time or inadequate data resolutions.

Analogue simulations synthesise continuous variables with a realism that is unattainable by digital methods.

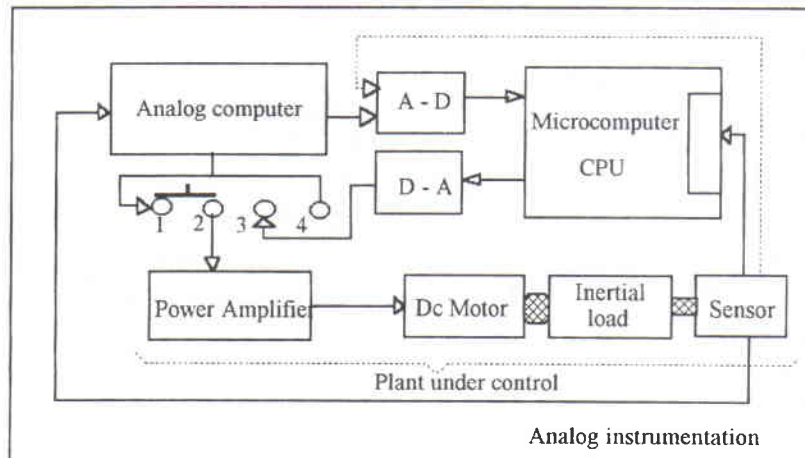

Fig.1. The configuration of Workstation

In such a configuration, the user may work easily and interchangeably in the following media:

- *Analogue Simulation.* Both the controller and mechanism to be controlled are simulated on the analogue computer.
- *Analogue Control of the Hardware.* The controller is patched and run from the analogue computer.
- *Digital Control of the Simulator.* The digital computer controls the analogue simulator.
- *Digital Control of Hardware.* The digital computer controls the hardware.
- *Analogue/Digital Control of a Combined Apparatus/Analogue Simulator.* By adding simulated poles and zeros, simple hardware is made to function as a more complex mechanism.

CONCEPTION & DESCRIPTION THE HARDWARE OF HYBRID SYSTEM

The hybrid system, Analogue Computer - Personal Computer (AC-PC), consists of the equipments shown in Fig.2.

The computer support system consists of a personal

- resolution (12 bit), bipolar, round off & quantisation and converter code (-10volt=2048Hex, 0volt=0000Hex, +10 volt=2047Hex);
- addressing and initialising of input/discrete output charts (24 lines, level TTL, addresses field 308-30f);
- measurement of the base time is reduced by timer of the A/D chart on 0.25 ms;
- sampling time of A/D chart is less then 100 mks.

Outline of Analogue Hardware

The most important features of analogue computer hardware's studies are (1) the analysis of roads that signals will perform, analogue signals (model inputs and nodes outputs) and discrete ones (control bus for the selection and direction of analogue signals); (2) signals level and necessary establishment through keyboard of analogue computer. On can train the communication AC - PC to obtain:

- the selection of physical model units (0,1,2), models input/output (1-8), the operation conditions (IC-initialisation, OP-operation, HD-fixation, RO-repeater operation).
- the setting of the development levels of potentiometers (1-8) within (0.00-1.00), initialisation

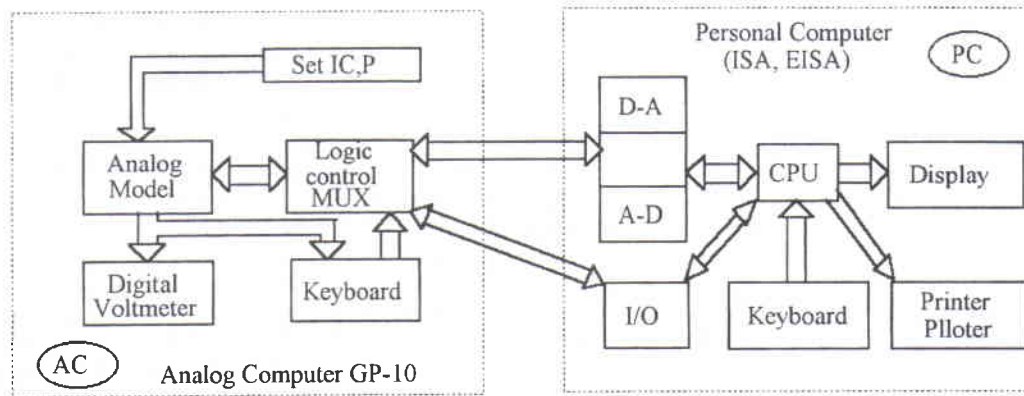

Fig. 2. Communication Analogue Computer - Personal Computer (AC-PC)

computer IBM PC, AT, and compatible. The necessary software to control analogue computer has been decided according the following characteristics:

- hardware interface between the analogue computer GP-10 and digital computer IBM PC;
- logical sequence of discrete signals.

Outline of Interface Hardware

The interface hardware analogue computer GP-10 and digital computer IBM PC realises the following functions:

- addressing of analogue bipolar signals (-10 + 10) volt (8 input channels) and (3 output channels) in the addresses fields;

conditions within (-10 +10) volt.

- to study the process in natural time period or speeded up till 400 times.

The main signals of analogue computer inner bus are shown in fig.3.

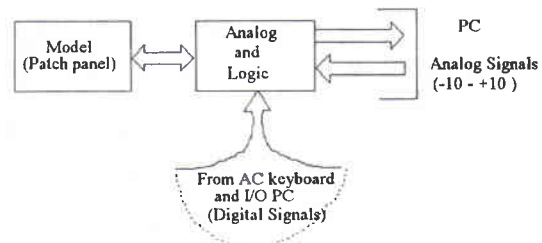

Fig.3 The inner bus of analogue computer

Outline of Digital Signals of Analogue Computer

The sequence of digital signals (PS HD OP TS) is decided from the operation conditions (IC OP HD RO) necessary for model study. The main vector of analogue computer digital models are shown in fig.4.

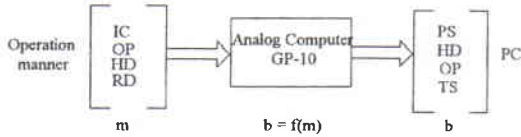

Fig.4 The vectors of analogue computer digital models

THE DEVELOPMENT OF HYBRID SYSTEM

It is most important to provide users with environment to understand the simulation results. The following describes newly the computer program to facilitate the interactive man-machine interface.

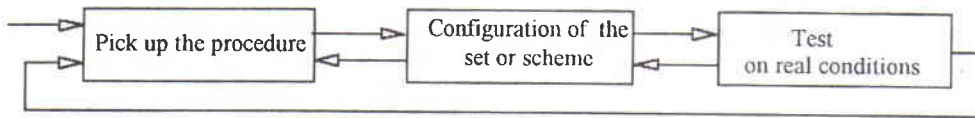

Fig.5. The development of the main dialogue structure

First decision is about the computer language. The computer languages like C and C++ offer the possibility to better administrate the charts and PC. During a rapid phenomenon, for example during calculation of rapid transient process of power system (part of second) the measuring and buffering of results are impossible even in C++.

That's why it was used Assambler language in this branch of informatique structure. Then, linking the Assambler modules with main informatique structure realised in C language, we obtain the optimal administration of hybrid AC-PC system. So, the main problems: velocity, graphical possibility, mathematics calculation, is now resolved.

The main structure of the system (fig.5) is conditioned by:

- the necessity of different procedures to be used, for example, the analogue computer testing, the visualisation of results of simulation, the remote control of hybrid model, etc.;
- the interactive man-machine interface as simple as possible, so that the users can operate easily, without special informatique knowledge's;
- the close loop structure offers the possibility of the reconfiguration, fast interface orientation and on-line interactive man-machine.

The overall configuration of system AC-PC with respective synoptic and procedures is shown in Fig.6.

The TEST procedure it is necessary not only for the

overall analogue computer physical testing, as well as for configuration of analogue computer. It is also necessary for the analogue simulation testing.

On the other hand, COM procedure (control, visualisation) is conditioned by the necessity to test time after time the hybrid model which will be simulated.

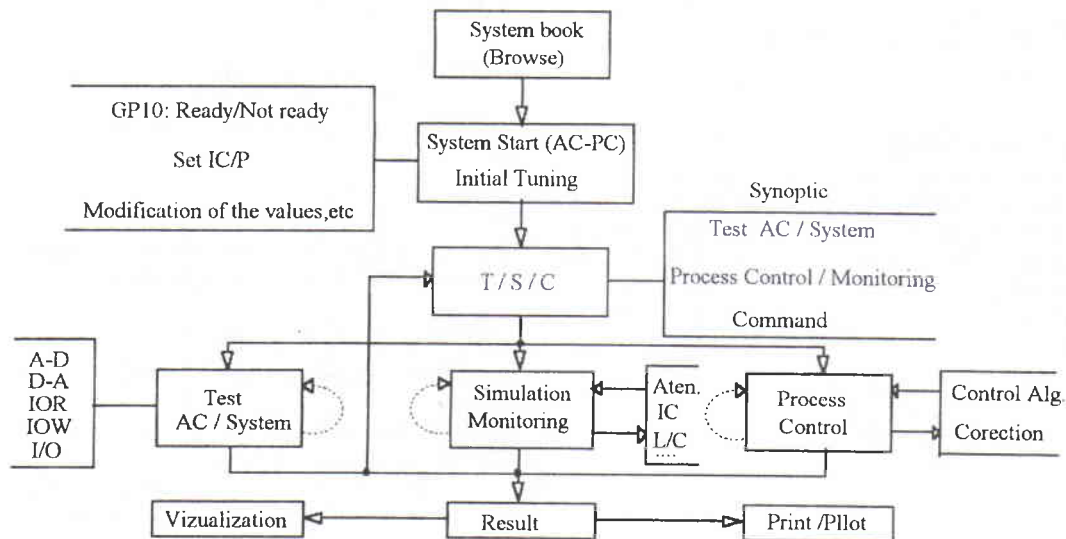

Fig.6. The overall configuration of AC-PC system.

Other important problem is the measurement and buffering of data (fig.7).

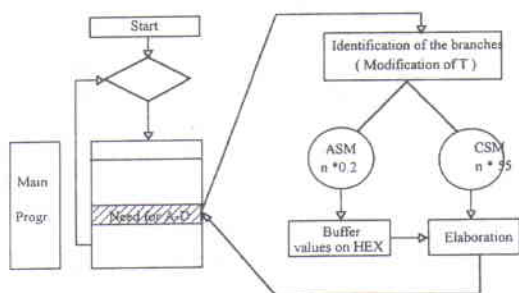

Fig.7. The configuration of measuring and data memorising in AC-PC system.

According the process to be simulated, the selection of different sampling time first from the users and then corrected from software is obtained.

EXAMPLES OF SIMULATION

Several examples have been calculated to demonstrate the effectiveness of hybrid simulation.

Example 1

In this example, we will simulate the system shown in fig.8 in two ways:

- a-with analogue simulation,
- b-with analogue control of the hardware.

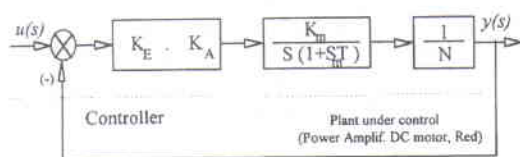

Fig.8 The block diagram of an automatic control system

a. Analogue Simulation

The analogue computer GP-10 is used for analogue simulation. Both the controller and the plant under control (fig.8) are simulated on the analogue computer. The personal computer is used for monitoring.

The mathematical model of above system is represented with the following differential equation system.

$$\begin{aligned} \frac{d^2y}{dt^2} + \frac{dy}{dt} + 2y &= 2u \\ y(0) &= 0 \\ \frac{dy}{dt} \Big|_{t=0} &= 0 \end{aligned}$$

The analogue model of the above controller and mechanism is shown in fig.9. A potentiometer evaluates the output angle. The load of DC drive with reduction coefficient N is an inertial load.

The parameters are: $K_m = \pi$ [rad/volt*sec], $T_m = 1$ sec, $N = 50$, $K_a = 10$, $K_e = 10/\pi$ [volt/rad].

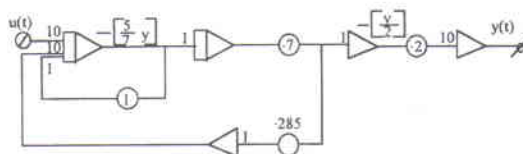

Fig.9 The analogue model of the controller and plant under control

The curve 1 in fig.10 represents the output angle response during the analogue simulation of the system.

b. Analogue Control of the Hardware.

The controller is patched and run from the analogue computer GP-10. The overall model consists of the analogue computer GP-10 and the Plant under control. The personal computer is used for monitoring.

The curve 2 in fig.10 represents the output angle response during the analogue control of the system.

The output responses of the model are close for both cases (fig.10).

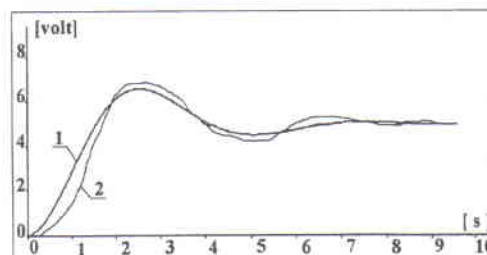

Fig.10 The output angle response of the system
1-with analogue simulation
2-with analogue control of the hardware

Example 2

In this example, we will simulate the voltage control system with digital control of analogue simulator.

c. Digital Control of the Simulator

The digital computer controls the analogue simulator.

The hybrid system model is based on the analogue representation of generator and exciter in the analogue computer GP-10 and digital representation of voltage control of generator in the personal computer. We use also the personal computer for monitoring.

The hybrid model is shown in Fig.11.

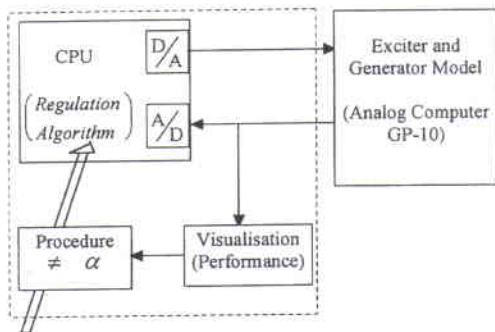

Fig.11. The hybrid model

The results of simulation using hybrid model is shown in fig. 12.

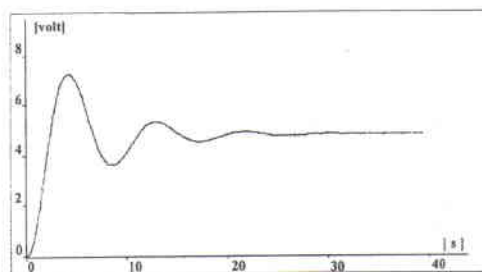

Fig.12 The response of hybrid model

Changing stabilising loop gain we can modify the response of the system and we can eliminate undesired oscillations and overshoot of the regulated voltage. We use the optimal procedure to calculate the stabilising loop gain. The response of hybrid model after stabilising loop gain correction is shown in fig.13.

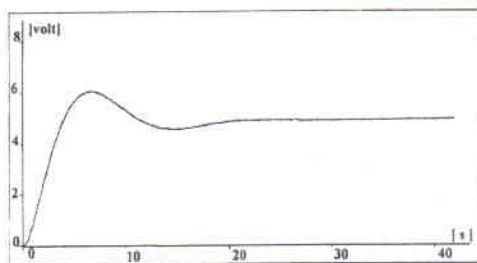

Fig.13 The response of hybrid model after stabilising loop gain correction

CONCLUSIONS

In this paper the analogue computer as part of a hybrid system for education and project development, as well as for a general engineering use or to a specific aspect of electric power system has been used.

The experience in the hybrid simulation uses for Analogue Simulation, Analogue Control of the Hardware and Digital Control of the Simulator is represented.

A hybrid system that include the analogue computer GP-10 and digital computer (PC) IBM PC, AT, and compatible for research, development and education is used.

The conclusion that the hybrid system is a necessary laboratory equipment for both education and project development, is emphasis.

REFERENCES

- [1] H.Doi, M.Goto, et al. "Advanced Power System Analogue Simulator" *IEEE Trans. on Power Systems*, Vol.5, No.3, pp.962-968, August 1990.
- [2] X.Wang, J.Giesbrecht, et al. "Enhanced Performance of a Conventional HVDC Analogue Simulator with a real time Digital Simulator" *Proceedings of IEEE PSCC 1993 Conference*, pp.663-671, 1993
- [3] R.H.Spices "Two Reasons why a Control Laboratory Needs an Analog Computer", Comdyna, Inc., 305 Devonshire Road, Barrington, IL 60010, USA.
- [4] B.Haas "Analogue and digital Computer Handbook", 1985.
- [5] Y.Sekine, K.Takahashi, T.Sakaguchi "Real-time Simulation of Power System Dynamics" *Proceedings of IEEE PSCC 1993 Conference*, pp.3-12, 1993.
- [6] J.Wang "Analysis and Design of an Analog Sorting Network", *IEEE Trans. on Neural Networks*, pp.962-971, Vol.6, no.4, July 1995.
- [7] L.Collamati, et al. "Induction Machine Stator Fault On-Line Diagnosis based on LABVIEW Environment", *Proceedings of MELECON'96, 8TH Mediterranean Electrotechnical IEEE Conference*, pp.495-498, Vol.1, May 1996.
- [8] P.J.Mosterman, G.Biswas "Principles for Modeling, Verification and Simulation of Hybrid Dynamic Systems", 5th Intl. Conf. on Hybrid Systems, pp.21-27, 1997.